



VELKOMMEN TIL PÅBYGGERSAMLING



SCANIA

PRESENTATØRER



Frode Andreassen

Produkttekniker

Ettermarked

Påbyggerkontakt

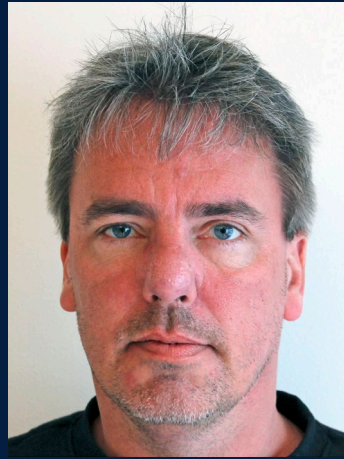

Robert Steen

Produkttekniker

Salgstøtte

Påbyggerkontakt



Kjetil Hansen

Fagleder

Produksjonsgruppe



Pål Rastad

Teknisk sjef

Ettermarked



AGENDA

- Ansvar og kvalitetssikring
- COW og oppfølging av påbygg i Norsk Scania
- Digitalt dashboard generell info
- Smart Dash
- Generelle sikkerhetsforskrifter (GSR)
- Scania Workshop Suite (SWS) / BICT
- Cybersikkerhet
- Grunnleggende sikkerhetsinformasjon om kjøretøy på gass og elektrisitet
- Ønsker / tilbakemeldinger (behov) fra påbyggere
- Chassistegninger – 2D / 3D + S-ordre
- Forberedelser på chassis
- Scania TBB / bruk og ny påloggingsrutine



KJETIL HANSEN & ROBERT STEEN

ANSVAR SOMRÅDER & KVALITETSSIKRING

SCANIA

USE AND RESPONSABILITY, LEGAL REQUIREMENTS

- TRUCK CERTIFICATES
- BUS CERTIFICATES
- STANDARDS
- CO2 AND COC
- DATABASE FOR INFORMATION ON SUBSTANCES OF CONCERN IN PRODUCTS (SCIP)



USE AND RESPONSABILITY. LEGAL REQUIREMENTS

Language

Select Language 

Filters



- Use and responsibility 
- Declaration of Conformity 
- Quality and safety inspection 
- Warranty and claims 
- Safety 
- Laws and regulations 

<https://truckbodybuilder.scania.com>



PÅBYGGERS ANSVAR

- Påbygg, eller ombygging må utføres i henhold til Scantias påbyggeranvisning
- All påbygging eller ombygging som ikke beskrives av Scania Truckbodybuilder-portalen, må godkjennes av Scania via FRAS
- Hver påbygger skal fylle ut en samsvarserklæring (DoC) – kan være flere på samme chassis
- Opprinnelig kvalitet og funksjon av chassiskomponenter skal opprettholdes når påbygg er ferdig fullført
- Påbygg skal tilfredsstillе juridiske, sikkerhetsmessige og hensiktsmessige krav
- Deler som påbygger har montert på chassiset, er tydelig merket med leverandørens navn og delenummer – tydelig merking gjør håndtering av reservedeler enklere for ettermarkedet

Form for large pre-delivery inspection (D)

Dealer		Customer name		
Date	Distance driven	Reg. no.	Work order	Vehicle/engine type:
Chassis serial number:	Operation type	Completed by	Signature of supervisor	

P, G, R and T series/P, G, R and S series

This inspection form is used if the following conditions are met:

- The vehicle is equipped and the bodywork built by an external bodybuilder.
- If the above condition is not met, carry out Small pre-delivery inspection (D).
- Save two copies of the pre-delivery form. One copy should be kept in the workshop and one in the vehicle binder.

 Carried out without comment

 Carried out with comment
The form applies to the P, G, R and S series

1	Bodywork, declaration of conformity: Check that the document is in the specified place in the vehicle. The document confirms that the bodywork has been completed in accordance with Scania rules.	00	
No.	In the maintenance area	Group	Completed
2	Cab: Fit and adjust the transport-mounted roof air deflector.	18	
3	Wheel nuts: Check-tighten.	09	
4	Tyres: Adjust the tyre pressure.	09	
5	Axle weight distribution: Check the axle weight distribution on vehicles with twin front axles.	13	
6	Steered axles: Check toe-in on all steered axles. On vehicles with more than one steered axle, the steered axles must be parallel.	13	
7	Gearbox: Check the oil level and check for leaks. The oil should be level with the edge of the level hole.	05	
8	Rear central gears: Check the oil level in the axle gears and any hub reduction gears. Check for leaks from the axle gears and hub reduction gears.	09	
9	Cooling system: Check the fluid level. Check the freezing point of the fluid: °C. Adjust if necessary.	02	





INSPEKSJON FØR LEVERING



Language
 Select Language ▼

Filters

- Use and responsibility ▼
- Declaration of Conformity ▼
- Quality and safety inspection ▼**
 - Pre-delivery inspection: Instructions ▼**
 - Pre-delivery inspection: Checklist ▼**
- Warranty and claims ▼
- Safety ▼
- Laws and regulations ▼

VEHICLE INFORMATION

Vehicle id (VIN code)

Bodywork:

Bodybuild:

Date:

Signature:

Name:

Stamp:

1. Documentation

No	Docu
1.1	Pre-c
1.2	Decl
1.3	The u
1.4	Instri
1.5	Form
1.6	Docu
1.7	Form
1.8	Desc

2. Legal requirements and technical requirements

No	Docum
2.1	Equipm
2.2	Equipm
2.3	Equipm
2.4	For veh
2.5	Undern
2.6	Total w
2.7	Mudflap
2.8	Vehicle
2.9	Lighting

3. General requirements

No	Inspec
3.1	The vel
3.2	The su
3.3	The bo
3.4	The bo
3.5	A manu
3.6	The Me
3.7	Fluid re
3.8	The ar
3.9	Flamm
3.10	Distan
3.11	Clampi
3.12	Paintw
3.13	Subfra
3.14	The eff

4. Hydraulic system:

No	Inspection	Not applicable	Fulfilled	Not fulfill
4.1	Hydraulic pipes have been used where possible			
	The type of hydraulic hose used is documented as follows:			
	Manufacturer:			
4.2	Type of hose:			
	Heat resistance:			
	Pressure resistance			
4.3	Hydraulic hoses are positioned more than 100 mm from hot components			
4.4	No couplings are positioned above hot components with temperatures higher than 250°C			
4.5	Hoses and pipes are designed so that leakage will not come into contact with hot components			
4.6	The hydraulic pump is protected from high heat			
4.7	Clearance between the components in the hydraulic system and components attached to the chassis			
4.8	Hoses and pipes have strain reliefs at max. 300 mm between them			
4.9	Hydraulic hoses are installed in a way that minimises the risk of chafing. Chafing covers are fitted in exposed positions.			



INSPEKSJON FØR LEVERING

- En inspeksjon før levering er obligatorisk for å sikre påbyggingskvalitet
- Minimum sjekkpunkter i henhold til Scantias sjekklister
- Påbyggere har lov til å bruke egen sjekklister
- Oppbevar sjekklister, i det minste til garantitiden er ute



DECLARATION OF CONFORMITY - DOC

SAMSVARSERKLÆRING

DIGITAL SIGNERING AV DOC



Bodybuilder

First name *

Last name *

Company name *

Street address *

Postalcode/zipcode *

City *

Email *

Mobile number *

Vehicle

Vehicle Identification Number (VIN) *

Bodywork

Bodywork type *

Bodywork serial no *

Quality and safety inspection *

Quality and safety inspection has been done according to the document Pre-delivery inspection: Checklist.

Conformity to Scania bodywork instructions *

Deviations documented and communicated with Scania.

Scania FQCA no's *

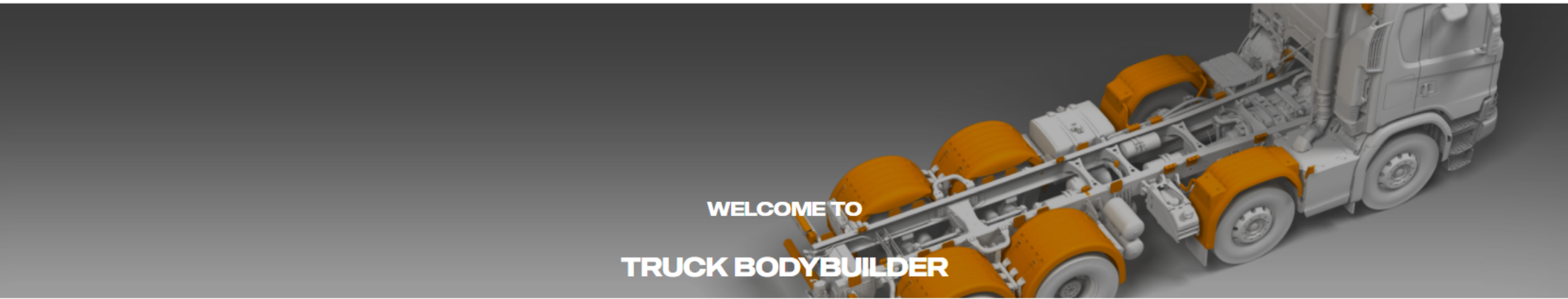

REQUIREMENTS WHEN BODYBUILDING ON A SCANIA VEHICLE

BODYBUILDER REQUIREMENTS

All bodybuilding and conversions must be carried out in accordance with Scania's bodywork instructions given on this website.

If there is a need for a solution not covered in the Scania bodybuilding instructions, it is required to retrieve an approval from a Scania dealer before the bodybuilding or conversion starts.

The dealer will apply to Scania for approval of the bodywork design. Approval is required in order for the factory warranty to apply.

This applies both for new and used vehicles.

[USE AND RESPONSIBILITY](#) →

REQUIREMENTS FOR DOCUMENTED INSPECTION

For every bodybuilding and conversion work, the bodybuilder must certify that the bodywork and bodybuilding has been carried out in accordance with Scania's bodybuilding instructions in order for the Scania factory warranty to apply.

This can be done by using the quality and safety inspection, as well as the declaration of conformity, available in the bodybuilder information.

It is possible for bodybuilders to use their own inspection documentation after it has been approved by Scania.

DECLARATION OF CONFORMITY



The DoC can be digitally signed with a mobile phone or printed and signed manually.

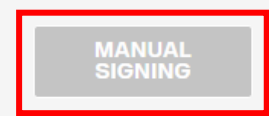



UNNTAK FRA PÅBYGGGS- INSTRUKSJONER

UNNTAK FRA KRAV



Bodybuilder

First name *

Last name *

Company name *

Street address *

Postalcode/zipcode *

City *

Email *

Mobile number *

Vehicle

Vehicle Identification Number (VIN) *

Bodywork

Bodywork type *

Bodywork serial no *

Quality and safety inspection *

Quality and safety inspection has been done according to the document Pre-delivery inspection: Checklist.

Conformity to Scania bodywork instructions *

Deviations documented and communicated with Scania.

Scania FQCA no's *



Product queries in addition to those described in Scania's bodywork instructions

Scania must be contacted for evaluation in any case where the bodybuilder wishes to deviate from Scania's bodybuilder instructions.

Scania provides one of the following 3 replies to the request for bodywork or conversion:

- Approved.
- Allowed
- Rejected

Approved.

The technical solution is approved, which means that Scania accepts liability for the solution from a chassis perspective. Scania's standard warranties therefore remain unchanged for Scania parts.

Allowed

The technical solution is allowed, which means that Scania permits the solution but the person or entity carrying out the work bears liability for it. Scania's stance is that the solution may affect Scania components to a certain degree. As the solution has not been verified by Scania, the bodybuilder bears the liability. Where the bodybuilder's solutions or modifications affect Scania parts, these Scania parts will not be covered by Scania's warranties.

Rejected

The technical solution is rejected, which means that the bodybuilder is not permitted to implement the solution on the Scania chassis.



KJETIL HANSEN

COW / OPPFØLGING AV PÅBYGG I NORSK SCANIA

SCANIA



PRODUKSJONGRUPPEN

Innhente og distribuere informasjon

Ca 200 aktører

Ca 23000 oppdateringer i COW system (pr.2023)

Aktivitet	Aktør	Koordinator - Utkast					Aktør				
		Land	Lt	Utkast for startdato	Utkast for sluttdato	Bekreftet	Lt	Startdato	Sluttdato	Forskjell	Kommentar
Levering fra fabrikk	Factory Södertälje		-	2024-12-09	2024-12-09	<input checked="" type="checkbox"/>		2024-12-09	2024-12-09		CDD Received
Påbygger	Påbygg	NO	5	2024-12-10	2024-12-16	<input type="checkbox"/>		2024-12-10	2024-12-16		
Påbygger	Trekking	NO	38	2024-12-17	2025-02-06	<input type="checkbox"/>		2024-12-17	2025-02-06		13.08.24 - Uke 6;
Påbygger	Lakking	NO	1	2025-02-07	2025-02-07	<input type="checkbox"/>		2025-02-07	2025-02-07		
Verksted	Hønefoss	NO	25	2025-02-10	2025-03-14	<input type="checkbox"/>		2025-02-10	2025-03-14		
Overlevering til kunde			1	2025-03-18	2025-03-18	<input type="checkbox"/>		2025-03-18	2025-03-18		



PRODUKSJONGRUPPEN - FERDIGDATO

- Sender totaloversikt hver andre uke

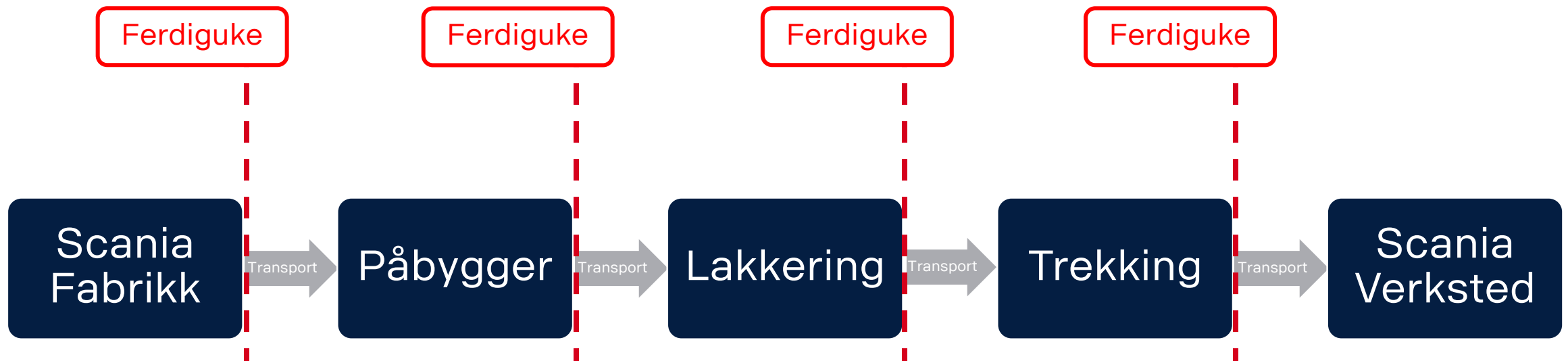

PRODUKSJONGRUPPEN - ANKOMSTDATO

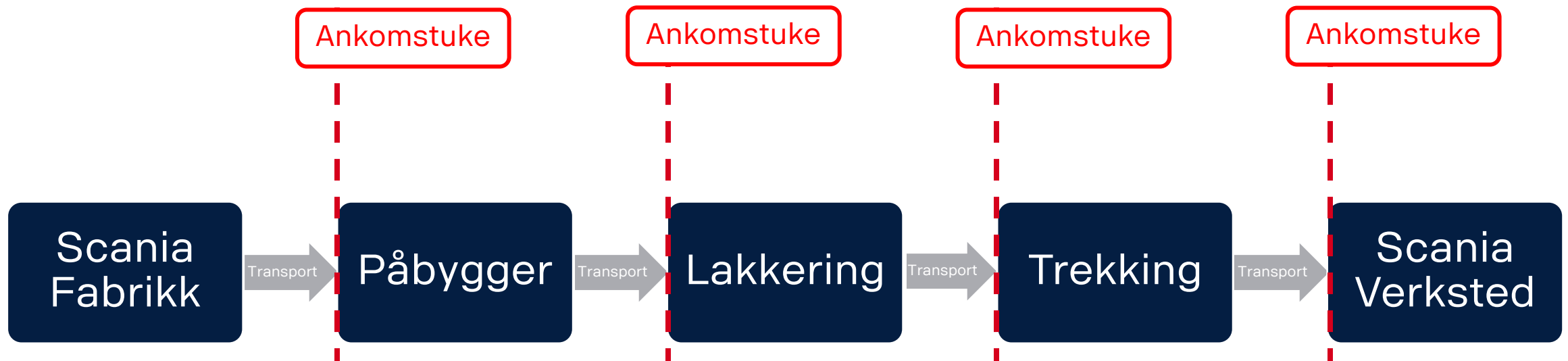



MOTTAKSKONTROLL HOS PÅBYGGER

- Hvordan håndteres mottak av chassis?
- Hva gjør aktøren som mottar chassis med skade?
 - Melde fra til ansvarlig part
- Hvorfor bør aktør gjennomføre mottakskontroll?
 - Sendes til sno.dokumentasjon.nybil@scania.com



TYSK LOVGIVNING

- Alle leverandører Norsk Scania AS benytter må være SCOC godkjent
- SCOC → Supplier Code of Conduct
- Ved spørsmål knyttet til dette kontakt innkjøpsavdeling for mer informasjon.

E-post sno.innkjop@scania.com



TOLL OG TRANSPORTER

- Hva blir nytt (2025)
- Splittfortolling blir ikke mulig å gjennomføre
- Eksport av chassis med påbygg ut av EU
 - Siste ledd i kjeden må lage komplett fortolling

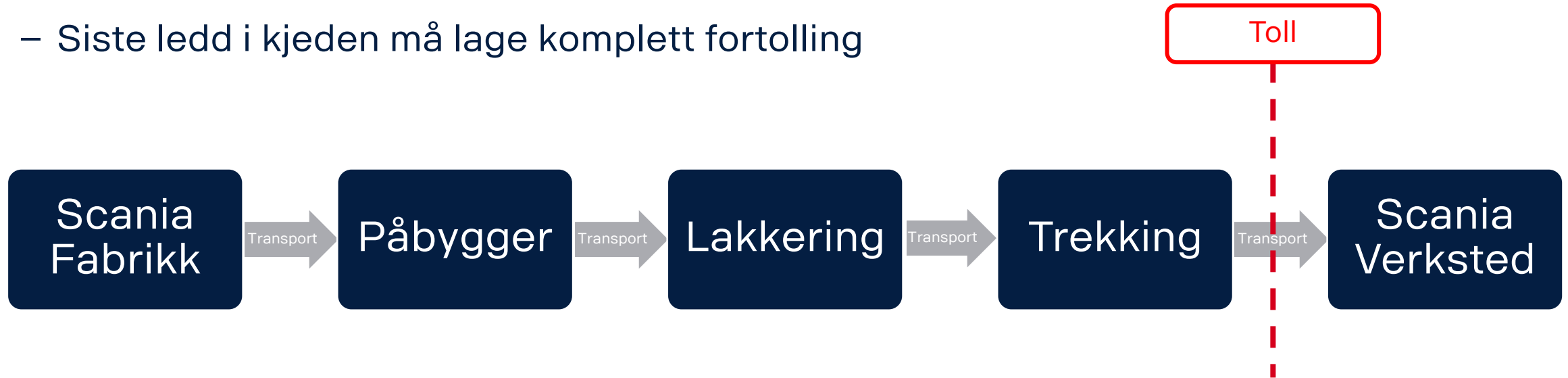



E-POSTADRESSER

- ❑ sno.koordinator.dss@scania.com
- ❑ sno.dokumentasjon.nybil@scania.com
- ❑ sno.innkjop@scania.com



FRODE ANDREASSEN, PÅL RASTAD & ROBERT STEEN

DIGITALT DASHBORD

GENERELL INFO

SCANIA



PÅBYGGERGRENSESNITT DIGITALT VS. ANALOGT

- Ingen endringer på påbyggers elektriske grensesnitts (BWE) hovedkomponenter

BCI (inkl. utvidelsesenheter)

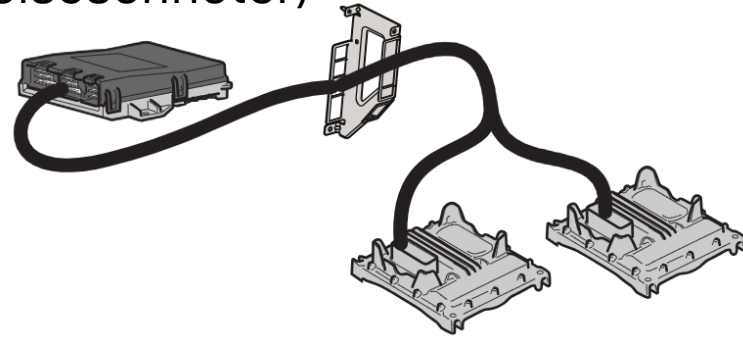

Påbyggskonsoll

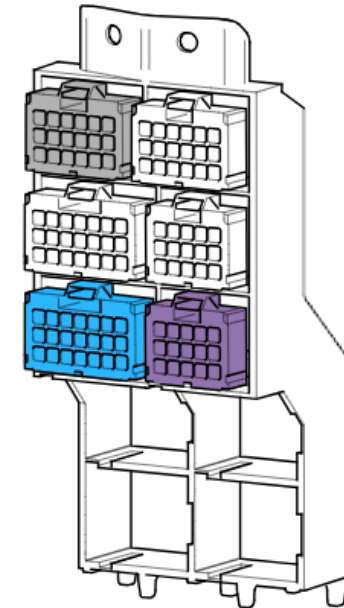

Elektriske sentraler for påbyggere (P9 & P11)

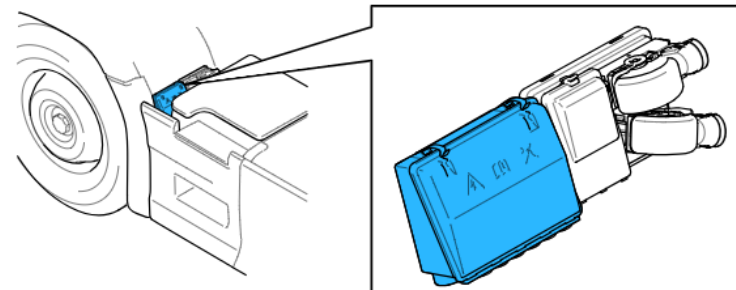
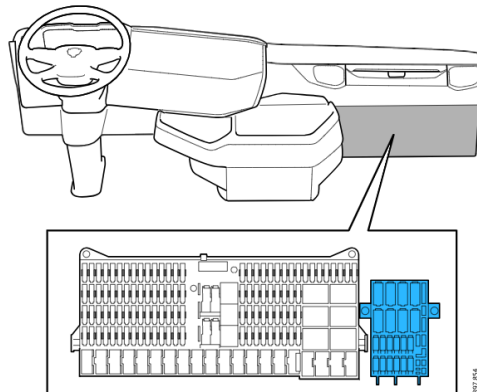

PÅBYGGERGRENSESNITT DIGITALT VS. ANALOGT

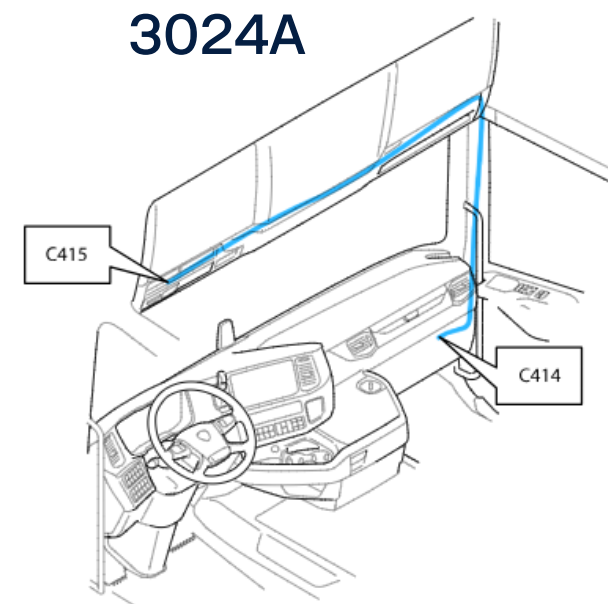
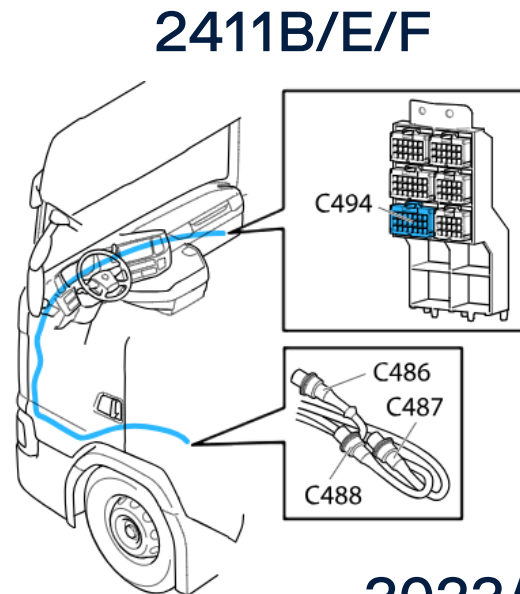
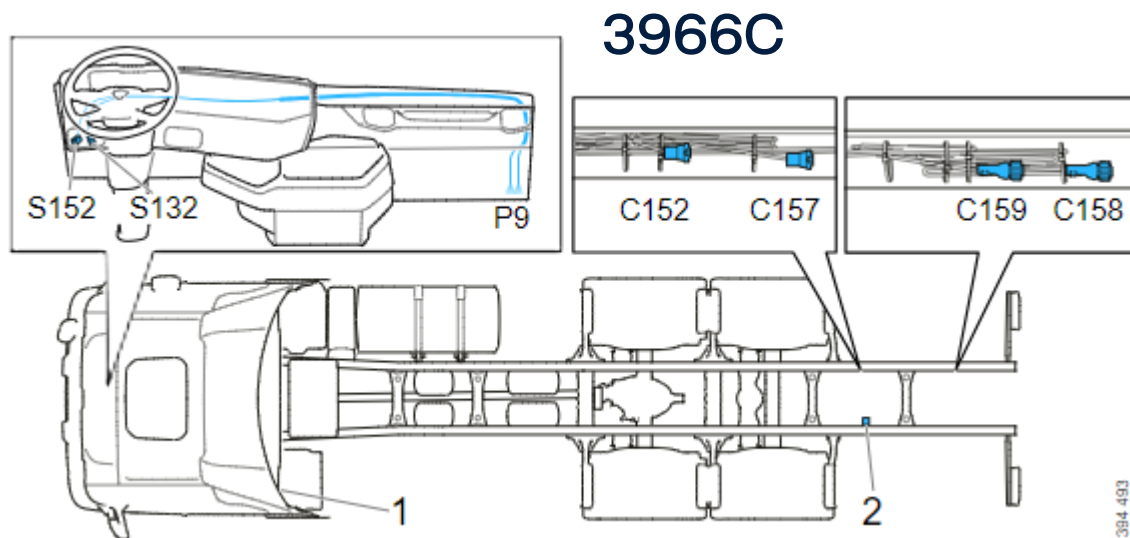

3023A/C/D

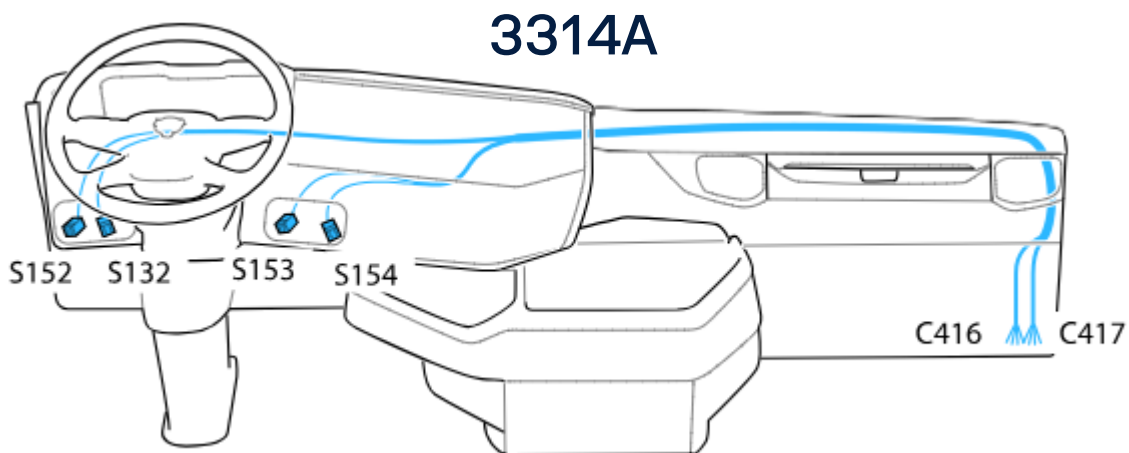
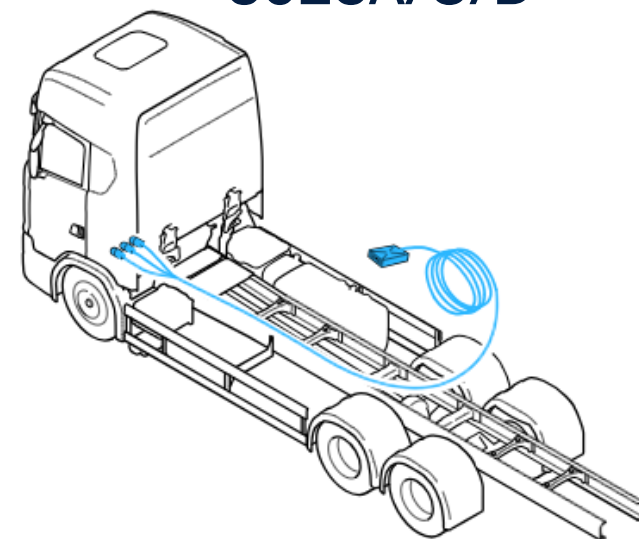



PÅBYGGERGRENSESNITT DIGITALT VS. ANALOGT

Påbyggerbrytere i Smart Dash

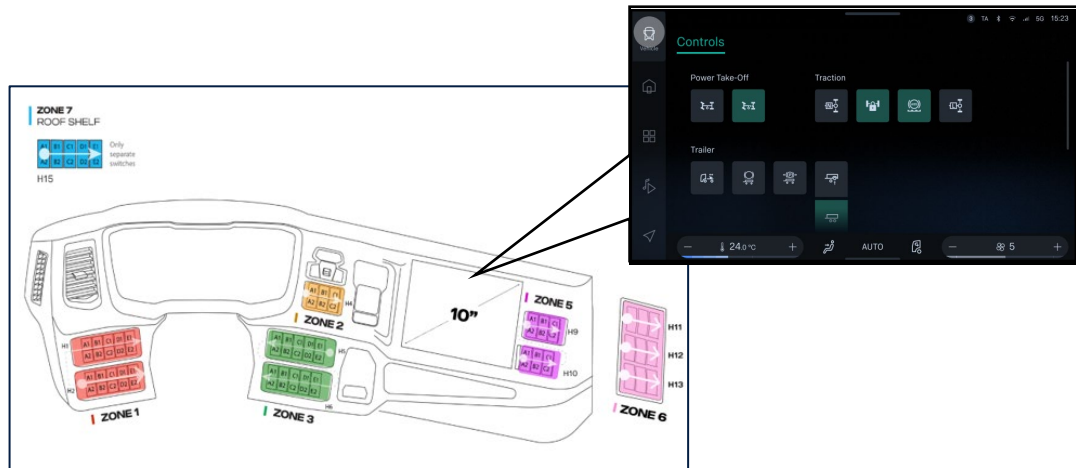

Avvikling av 12 V tilførsel

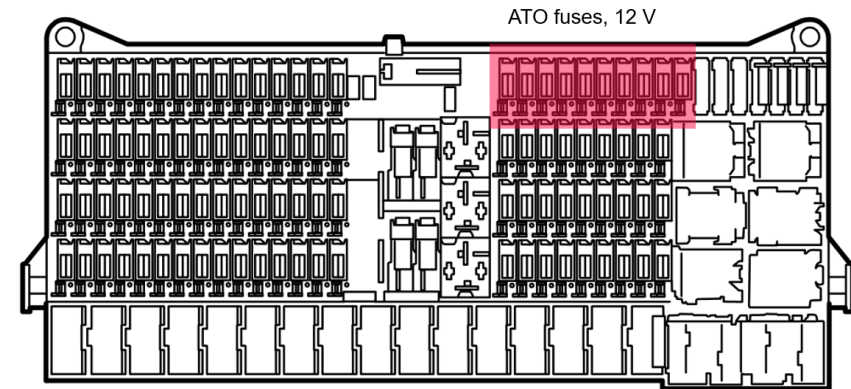

Påbyggerinformasjon i Smart Dash



GSR (ADAS) funksjoner

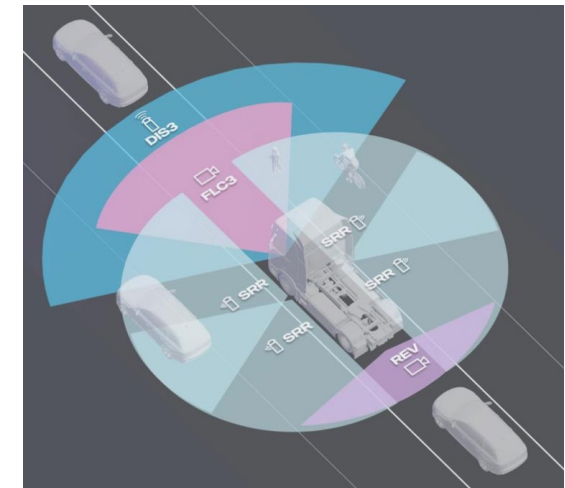



12 V FORSYNING AVVIKLET

- 24/12 V spenningsomformer, (EQU) avviklet i digitalt dashboard
- Ingen 12 V strøm tilgjengelig for påbyggere i P2
- Spenningsomformer, Pn. 1729858 (maks. 20 A) Anbefalt for påbyggere
- Retningslinjer for installasjon vil være oppdatert i BB-portalen

P2

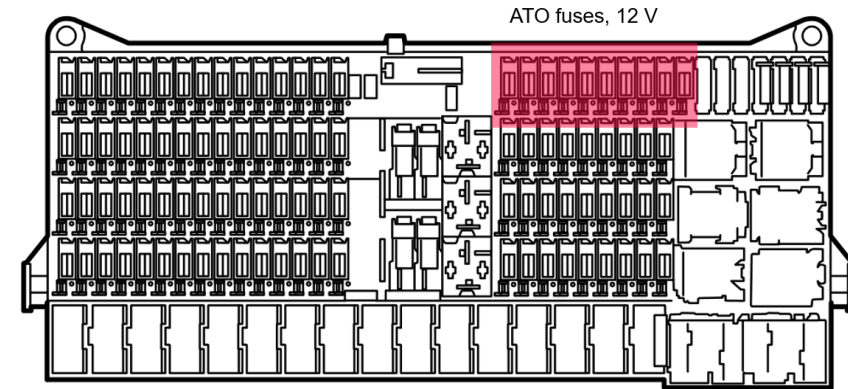



12 V OMFORMER

- **Standard førerhus:**
 - Ingen dedikert plassering
 - Ingen kabelforberedelse

- **Crew Cabs:**
 - Anbefalt plassering imellom klima system (E135, E136) i tak konstruksjonen
 - Ingen kabelforberedelse

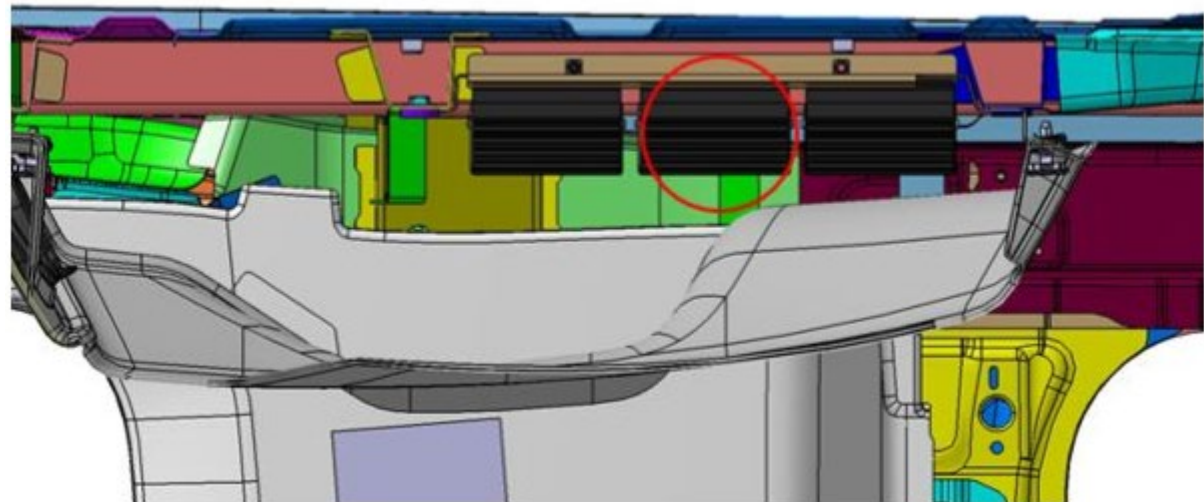
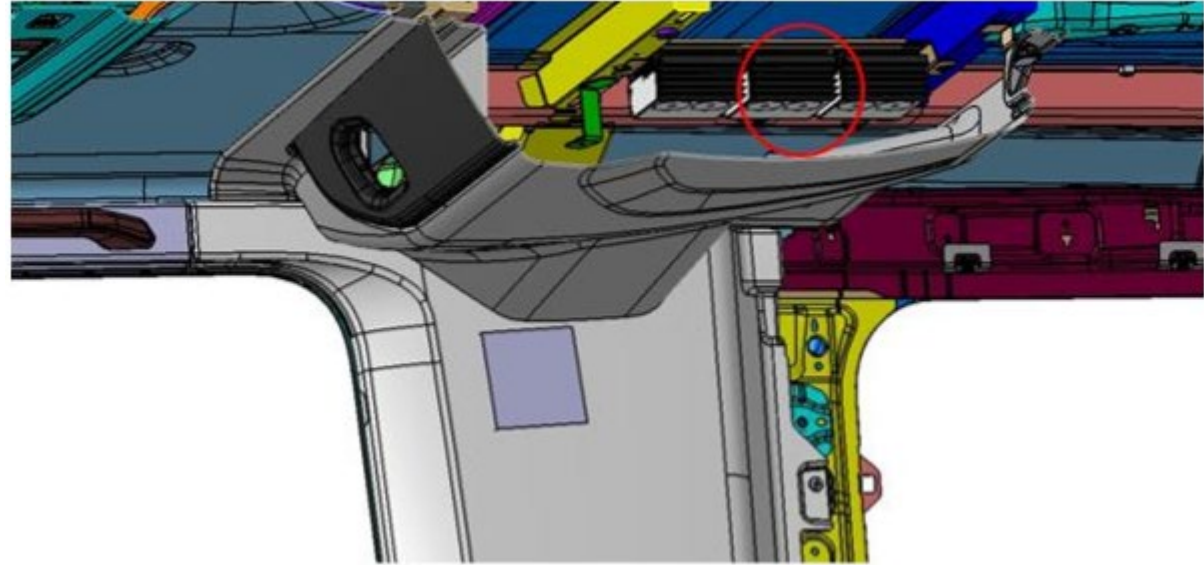



BATTERIOVERVÅKING

- Batteridatamodul (BDM) er koblet til 24V batteriets minuspole
- Koble aldri direkte til negativ pol ved lading, eller bruk av booster.
- Risiko for strømforstyrrelse under lading, hvis riktig tilkobling ikke er utført

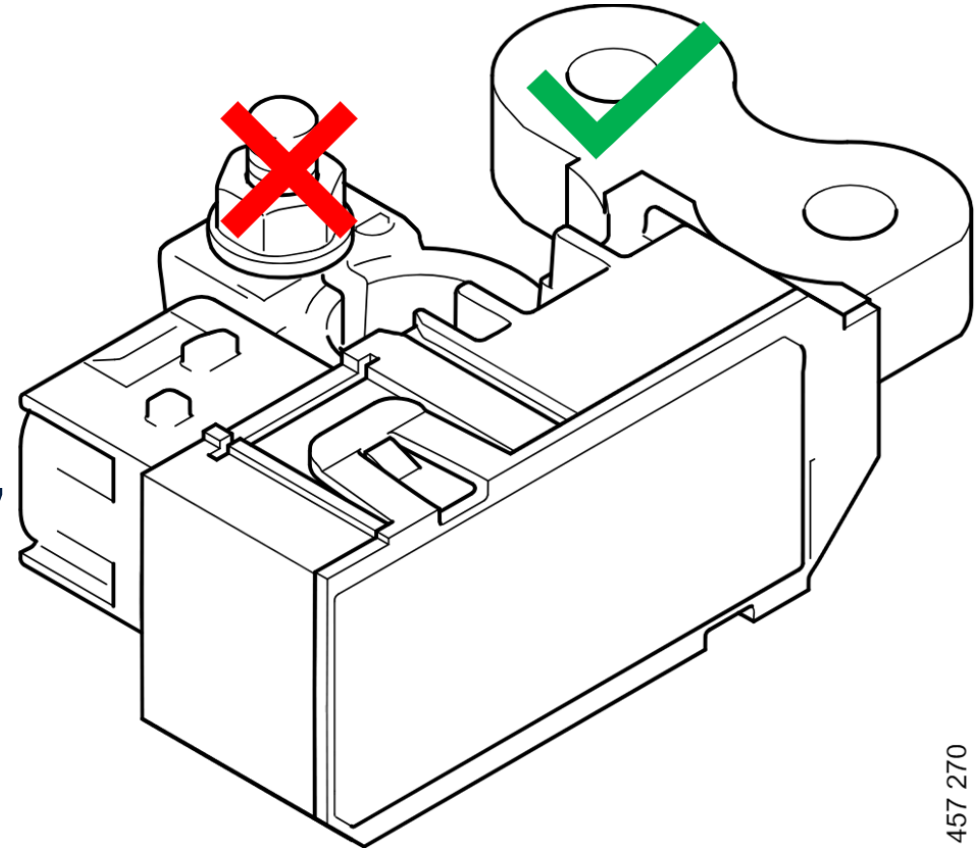



FRODE ANDREASSEN, PÅL RASTAD & ROBERT STEEN

SMART DASH

SCANIA

DDU

DRIVER DISPLAY

12.3"

CENTRAL INFORMATION DISPLAY

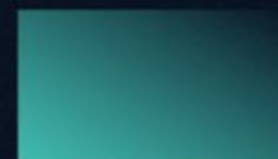

12.9"

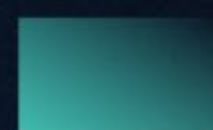

10.1"

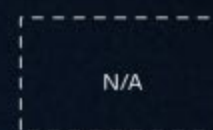

N/A

Without

DCP





PÅBYGGERBRYTERE

SCANIA



PÅBYGGERBRYTERE I SMART DASH

CID 10"



FPC 09488A

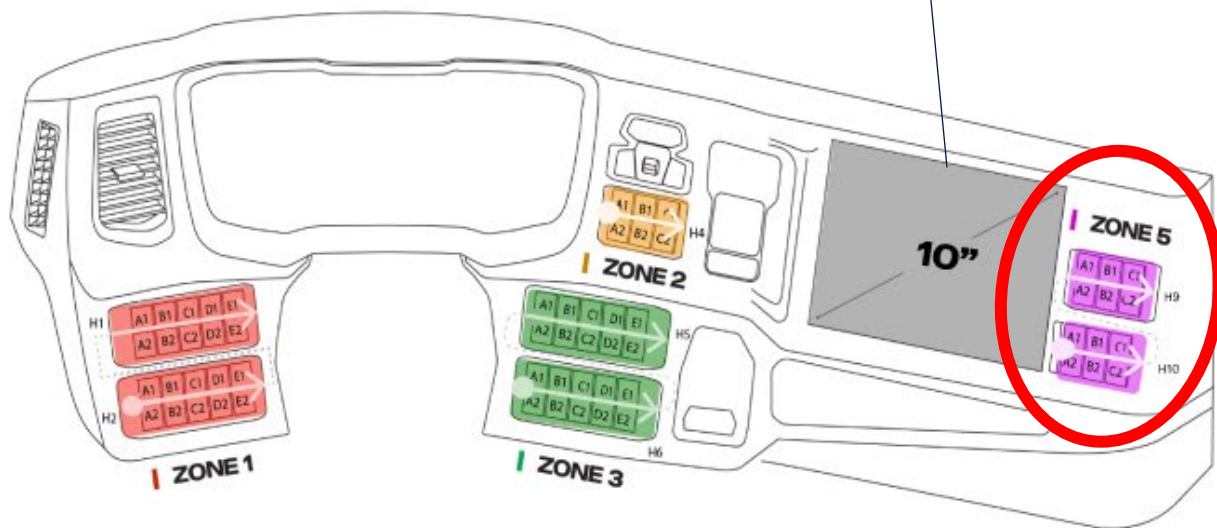

CID 12"



FPC 09488B

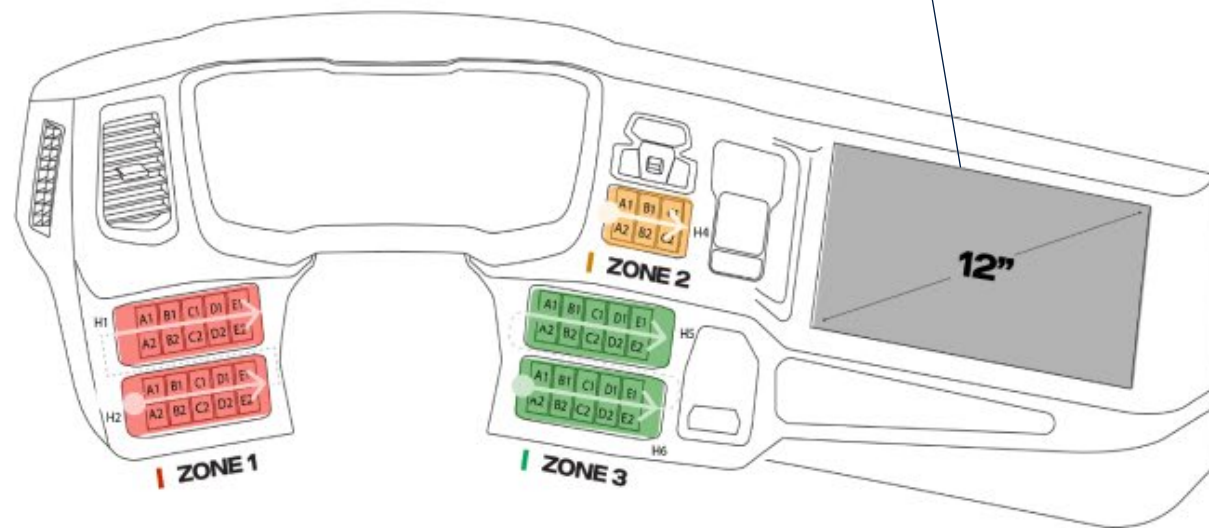



PÅBYGGERBRYTERE I SMART DASH

- Bare mekanisk brytere og CAN trykknapper er tilgjengelig for påbyggere
- Ikke mulig å bruke digitale knapper i CID

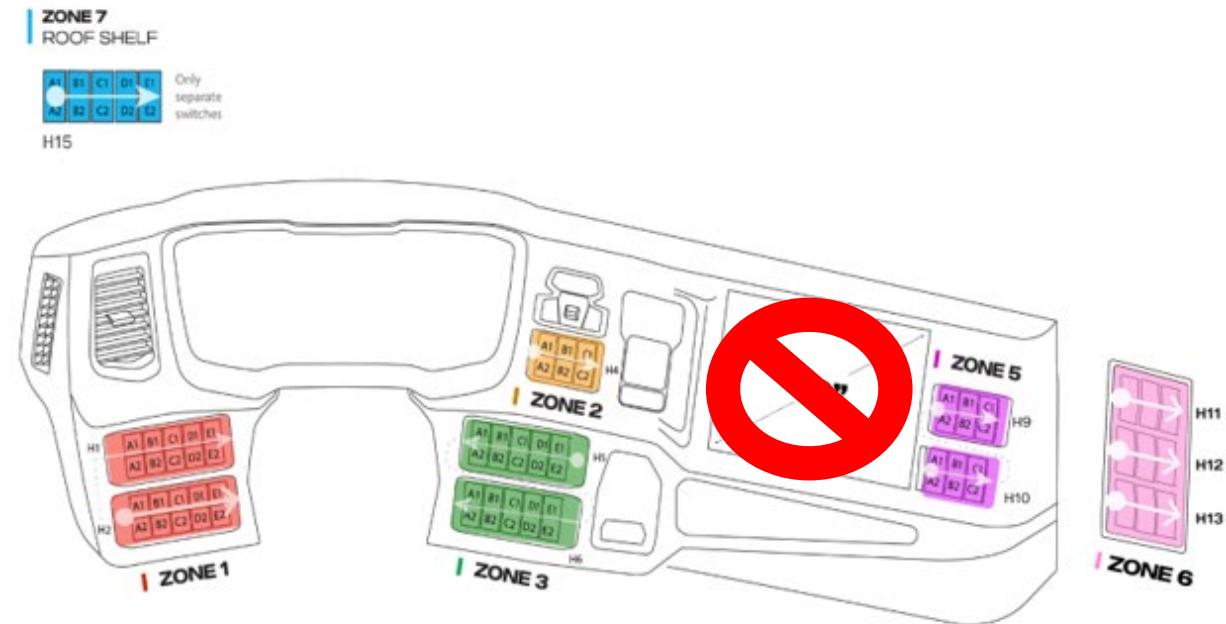



PÅBYGGERBRYTERE I SMART DASH

- CAN-trykknappene vil kun være tilgjengelige hvis kjøretøyet er spesifisert med variantkode 7682A: Forberedelse av påbyggsprogrammerbare brytere
- Mengden av tilgjengelige CAN-trykknapper og mekaniske brytere blir bestemt av følgende alternativer:
 - FPC 6793, *(CAN-) trykknapper* (2 – 10 stk)
 - FPC 7128, *(Mekanisk) brytere* (1 – 15 stk)



PÅBYGGERBRYTERE I SMART DASH



- Automatisk nøytral
- ABS terreng
- Bakkestart
- Tilhenger lufttilførsel
- Tilhenger bremsekontroll
- Kjøring frakoblet framaksel
- Fordelingskasse lavt gir
- Kjøretøy nivå kontroll
- Tilhenger akselløft
- Kraftuttak



PÅBYGGERBRYTERE I SMART DASH

- Løsning for en fysisk PTO knapp er mulig hvis kjøretøy er spesifisert med *Påbyggs kommunikasjonsgrensesnitt, BCI (FPC5837A)*
- Mekanisk bryter i Smart Dash

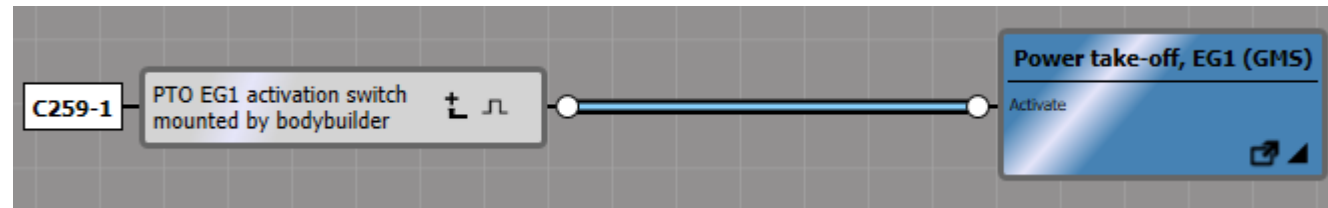

- CAN-trykknapp i Smart Dash

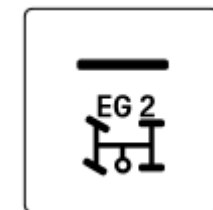
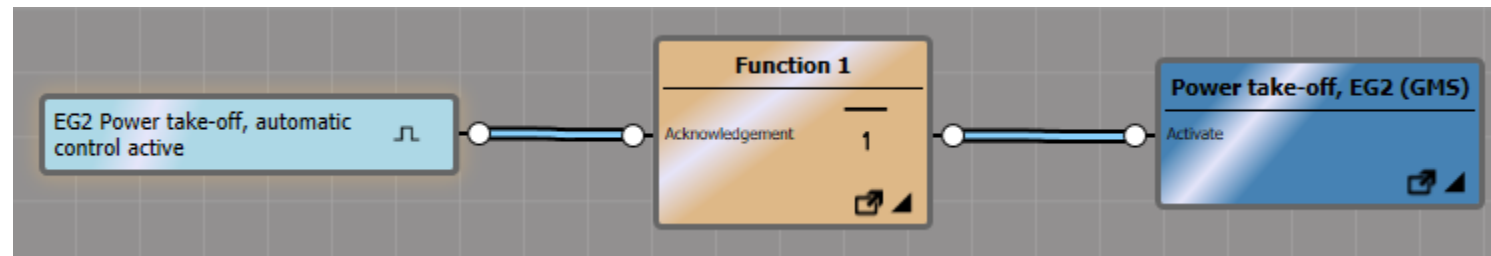



PÅBYGGER VARSELSYMBOL

SCANIA



PÅBYGGER VARSELSYMBOL

- Påbygger symbolskiver brukes ikke lenger i det digitale førermiljøet
- Gjelder også for tilpasset påbyggersymboler "klistremerkeløsning"

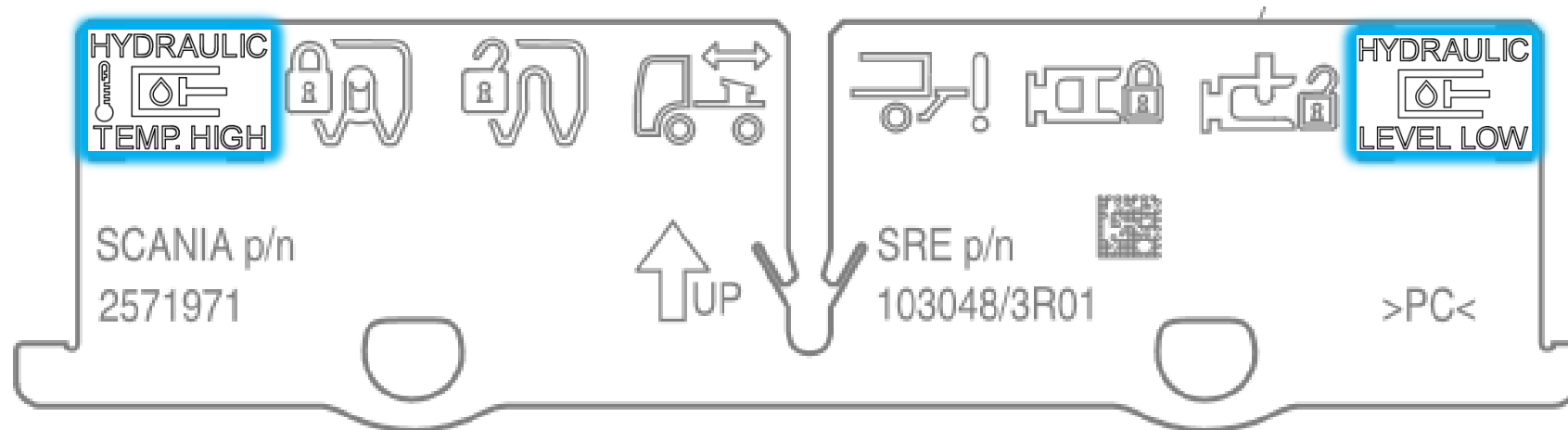



PÅBYGGER VARSELSYMBOL

- Påbyggersymboler i førerdisplay 1-8 (FPC 10222 - 10229)





PÅBYGGER VARSELSYMBOL

24.04

- Tilgjengelige FPC koder, 10222xx – 10229xx:

AA		symbol, bus door safety system disengaged	AS		symbol, EG1 power take-off	BK		symbol, reverse alarm off	CC		symbol, work light, left	CU		symbol, unlocked
AB		symbol, towing unit unlocked	AT		symbol, EG2 power take-off	BL		symbol, reversing light	CD		symbol, work light, right	CV		symbol, elektrically heated side window
AC		symbol, towing unit locked	AU		symbol, EG3 power take-off	BM		symbol, rotating beacon	CE		symbol, work light	CX		symbol, fifth wheel unlocked
AD		symbol, electrically heated windscreen	AV		symbol, vehicle fire warning	BN		symbol, sand spreader type 1	CF		symbol, spotlight	CY		symbol, battery saving mode
AE		symbol, heated windscreen wiper	AX		symbol, trailer tailboard spreader open	BP		symbol, sand spreader type 2	CG		symbol, temperature warning	CZ		symbol, fifth wheel locked
AF		symbol, low oil level, automatic oil filling	AY		symbol, tipper, trailer	BQ		symbol, sand spreader heater	CH	OFF	symbol, switched off	DA		symbol, low fuel level warning, heater
AG		symbol, central lubrication malfunction	AZ		symbol, truck tailboard spreader open	BR		symbol, supporting leg	CJ	ON	symbol, switched on	DB		symbol, disengaging bus stop brake
AH		symbol, door malfunction	BA		symbol, flashing light	BU		symbol, trailer axle lift 3	CK	EXT	symbol, external equipment permitted	DC	DOOR ALARM	symbol, door alarm
AJ		symbol, external lamp malfunction	BB		symbol, electrical wheelchair lift	BV		symbol, tipper body heating	CL		symbol, fifth wheel vertical adjustment	DD		symbol, EL power take-off
AK		symbol, passenger signal	BC		symbol, heating of surface	BX		symbol, tipper, truck	CM		symbol, fifth wheel horizontal adjustment	DE		symbol, open door
AL		symbol, school transport sign	BD		bogie drive roller	BY		symbol, cargo area lighting	CN		symbol, underrun protection lowered	DF		symbol, warning
AM		symbol, emergency hammer removed	BE		symbol, liquid level adjustment	BZ		symbol, daytime running light	CP		symbol, underrun protection raised	DG		symbol, floor heating
AN		symbol, EK power take-off	BF		symbol, automatic snow chain	CA		symbol, trailer axle lift 1	CQ		symbol, speed limiter	DH		Symbol, dual battery system
AP		symbol, split shaft power take-off	BG		symbol, platform locked	CB		symbol, winch	CR		symbol, electrically heated mirror	DJ		Symbol, tag axle lift
AQ		symbol, ED1 power take-off	BH		symbol, plough locked				CS		symbol, safety belt passenger	DK		Symbol, load transfer
AR		symbol, ED2 power take-off	BJ		symbol, plough in floating position				CT		symbol, locked			



PÅBYGGER VARSELSYMBOL

24.09

- Tilgjengelige FPC koder, 10222xx – 10229xx:

DL		Symbol, tag axle lift	DZ		Symbol, Light signal	EM		Symbol, Truck platform open	EZ		Symbol, Truck cargo light	FN		Symbol, Vehicle speed limiter 2	GA		Symbol, EE PTO
DM		Symbol Heating/cooling fan	EA		Symbol, Directional flash lamp	EN		Symbol, Trailer bodywork open	FA		Symbol, Battery master switch	FP		Symbol, Refrigeration auto mode	GB		Symbol, ED PTO
DN		Symbol, Tipper body vibrator	EB		Symbol, Directional flash lamp rear	EP		Symbol, Refuse packer step	FB		Symbol, Dual battery master switch	FQ		Symbol, Tail lift active	GC		Symbol, EM PTO
DP		Symbol, Bodywork cover open	EC		Symbol, Load tipping left side	EQ		Symbol, Truck body raised	FC		Symbol, Extra light	FR		Symbol, Roof sign light	GD		Symbol, Radio permitted
DQ	B 100	Symbol, bad concentration of B100	ED		Symbol, Load tipping right side	ER		Symbol, Truck demountable body unlocked	FD		Symbol, Air conditioning	FS		Symbol, Working lamp engine	GE		Symbol, External light trailer
DR	B 100	Symbol, bad concentration of B100 second warning	EE		Symbol, Watering	ES		Symbol, Bodybuilder box unlocked	FF		Symbol, On / Off	FT	35L	Symbol, Hydraulic 35L low	GF		Symbol, Hook loader arm out
DS	EG T	Symbol, EG T PTO	EF		Symbol, IR lighting front	ET		Symbol, Truck body mixer	FG		Symbol, PTO aborted	FU	70L	Symbol, Hydraulic 70L low	GG		Symbol, Vehicle speed limiter 3
DT		Symbol, Hatch open	EG		Symbol, IR lighting rear	EU		Symbol, Trailer cargo heating	FH		Symbol, Hook loader arm in	FV	MAN	Symbol, Manual mode			
DV		Symbol, Towing equipment	EH		Symbol, Radio silence	EV		Symbol, Trailer cargo refrigeration	FJ		Symbol, Winch out	FW	RADIO	Symbol, Radio			
DW		Symbol, Power Take Off	EJ		Symbol, Spotlight low	EW		Symbol, Crane cab heating	FK		Symbol, Winch in	FX		Symbol, Camera			
DX		Symbol, Trailer axle lift 3 rd of 3	EK		Symbol, Auxiliary heater	EX		Symbol, Crane cab fan	FL		Symbol, Winch freeheeling	FY		Symbol, Height control			
DY		Symbol, Trailer axle lift 1 st of 3	EL		Symbol, Immobilizer failure	EY		Symbol, Load transfer reverse	FM		Symbol, Noise reduction active	FZ		Symbol, Trailer maximum angle warning			



PÅBYGGER VARSELSYMBOL

- FPC 10222 – 10229 spesifiseres i selgerverktøyet
- Ettermarkedet har mulighet til forandre symboler i SWS-parameteren uten endring av SOPS
- I tilfelle utførelsen "Z" = uten er valgt for noen av varsellysene - vil ingen indikasjonslampe tennes selv om det blir bedt om det
- Om et marked krever at et nytt symbol legges til symbolbiblioteket – må dette må bes om via PRS.



PÅBYGGER VARSELSYMBOL

- FPC 5837A (*Bodywork Communication Interface, med*)
 - Mulig å aktivere 8 stk varselsymbol
 - Aktiveres med:
 - BICT
 - External CAN
 - Tilkoblet inngangssignal til BWE kobling C234 (stift 6 eller 8)
- FPC 5837Z (*Bodywork Communication Interface, uten*)
 - Mulig å aktivere kun 2 stk varselsymbol
 - Tilkoblet inngangssignal til BWE kobling C234 (stift 6 eller 8)

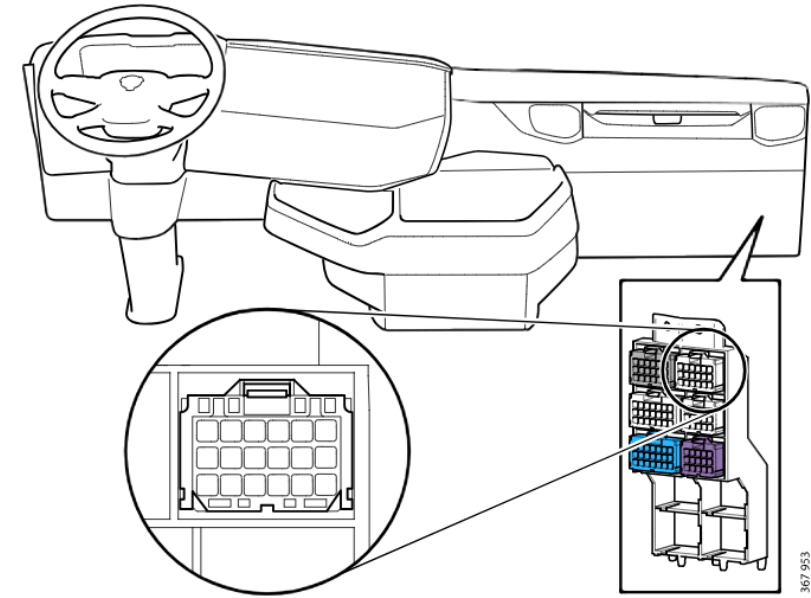

Harness-to-harness connector C234 with position in the bodywork console.



PÅBYGGER VARSELSYMBOL

- Aktivering av varselsymbol er lignende som i analogt system

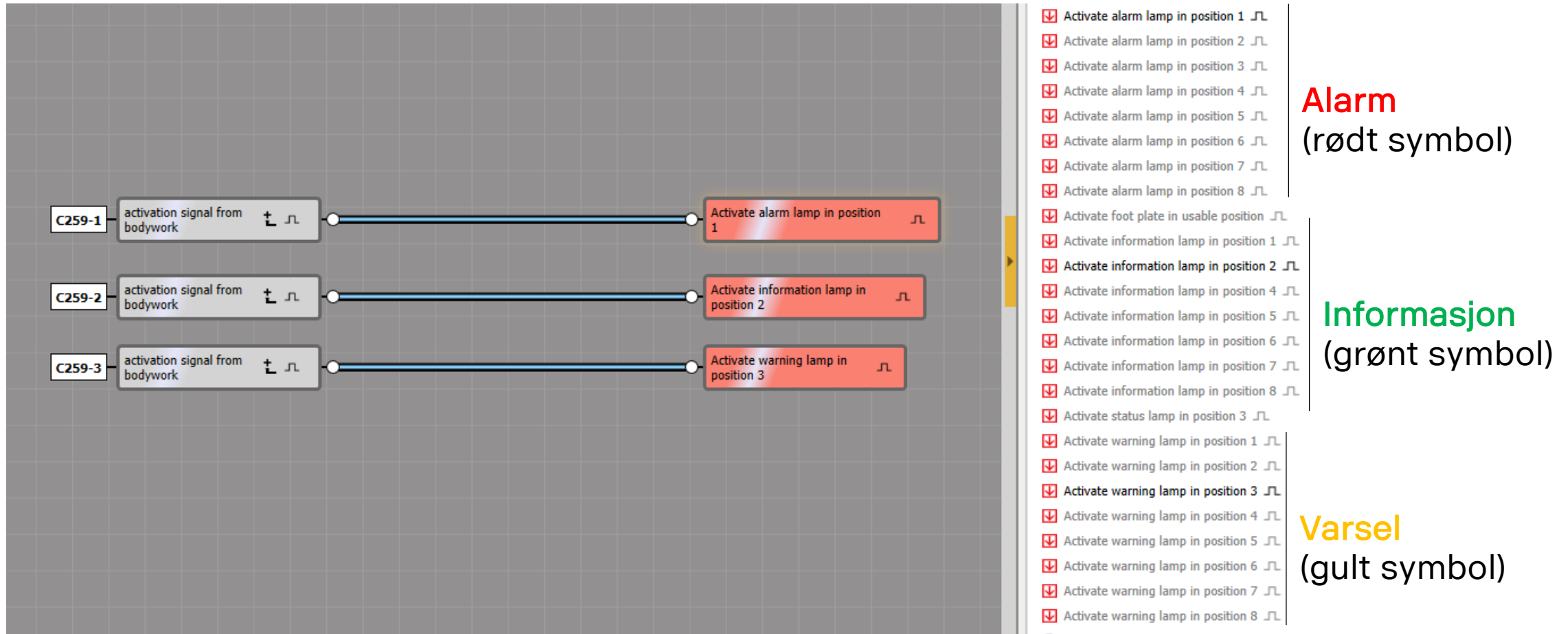



ANNEN PÅBYGGERINFORMASJON I SMART DASH

SCANIA



AKUSTISKE SIGNALER

- Overføring fra analogt system
- Enkle og kontinuerlige alarm- og varsellyder





INFORMASJON OM PÅBYGG

- Informasjon om påbygg (UF269) er utgått
- Ny løsning skal utvikles for å vise dynamisk påbyggsinformasjon i digitalt førermiljø

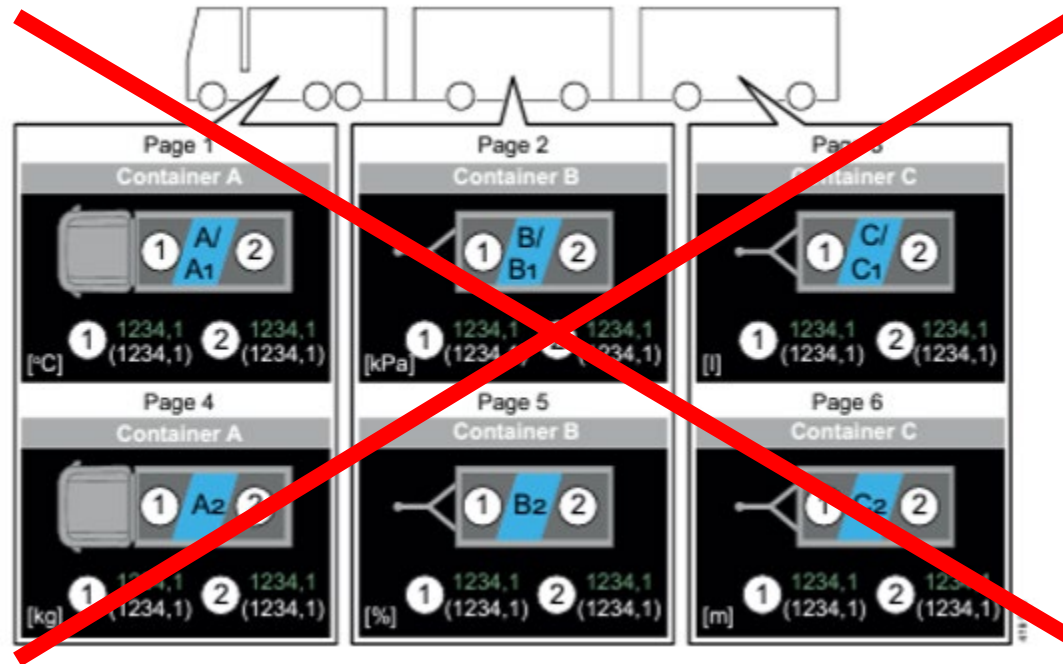



ROBERT STEEN

GENERAL SAFETY REGULATIONS (GSR)

SCANIA

SCANIA SAFETY

In compliance with the latest General Safety Regulation 2024

FPC 2811A



UNECE R48 | ESS
Emergency Stop Signal

Emergency Break Indication

FPC 8775A

UNECE R151 | BSIS
Blind Spot Information System

Vulnerable Road User
Collision Warning - Side

FPC 9824A/B

UNECE R158 | REIS
Reversing information system

Vulnerable Road User
Detection - Rear

FPC 9631A

EU 2021/1341 | DDAW
Driver Drowsiness and
Attention Warning

Driver Attention Support

FPC 7261A

UNECE R141 | TPMS
Tyre Pressure Monitoring System

Tyre Pressure Monitoring

FPC 3549A

EU2021/1958 | ISA
Intelligent Speed Assistance

Speed Sign Information

FPC 9103A

UNECE R159 | MOIS
Moving off information system

Vulnerable Road User
Collision Warning - Front

FPC 9105A

EU 2021/1243 | ALC
Alcohol Interlock
Installation Facilitation

FPC 3693B

Alcolock prep with/without



HW overview representation

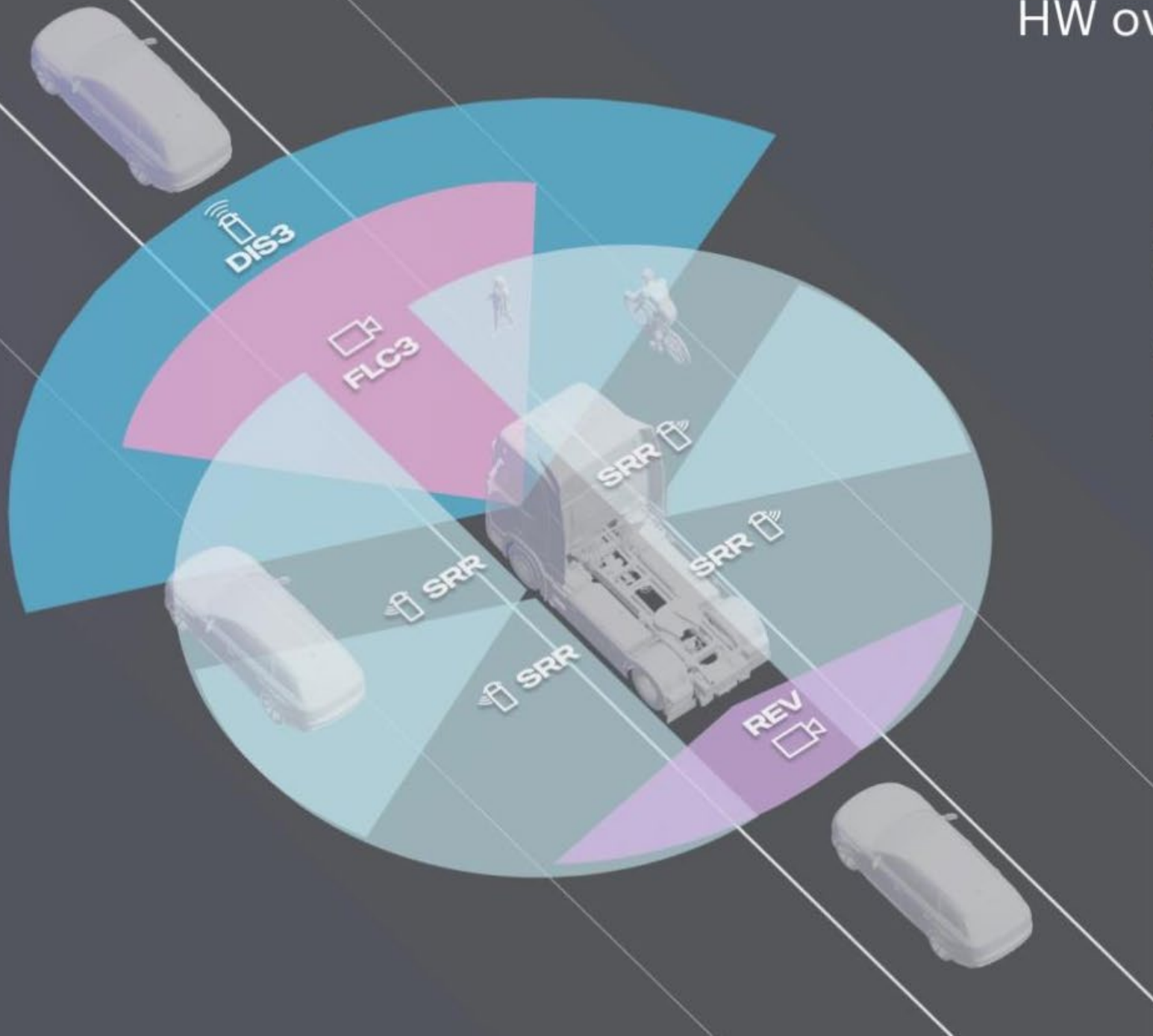

DIS - Distanse Sensor
(mid range radar)

FLC - Forward Looking Camera
(multi purpose intelligent camera)

SRR - Short Range Radar

REV - Reverse camera



KAMERA GRENSESNIITT (INKL. RYGGEDETEKSJON)

SCANIA



GENERELL INFORMASJON

- Kameravisning primært i det sentrale informasjonsdisplayet (CID)
- Ingen CID (buss) - kameravisning presentert i førerdisplay (DD)
- 3 analoge kameraportener i DDU kontrollenhet
 - Kamerainngang analog 1 (FPC 9573A)
 - Kamerainngang analog 2 (FPC 9574A)
 - Kamerainngang analog 3 (FPC 9575A)

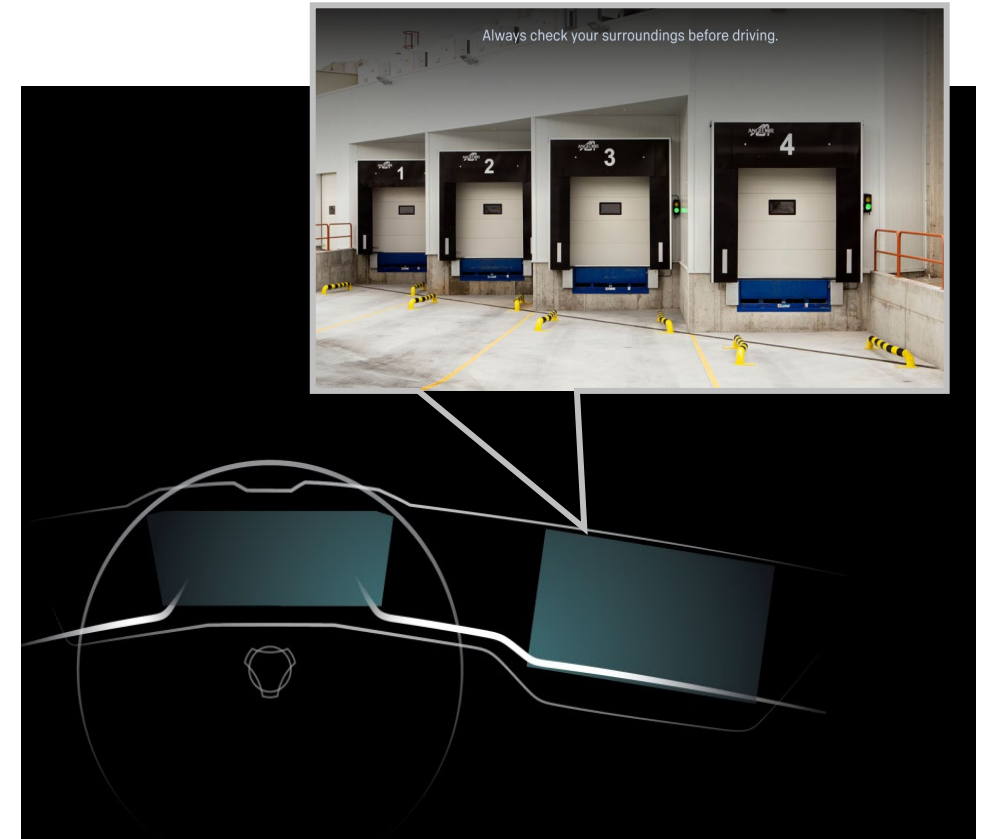



GENERELL INFORMASJON

- Mulighet for delt kameravising fra alle analoge kameraportner

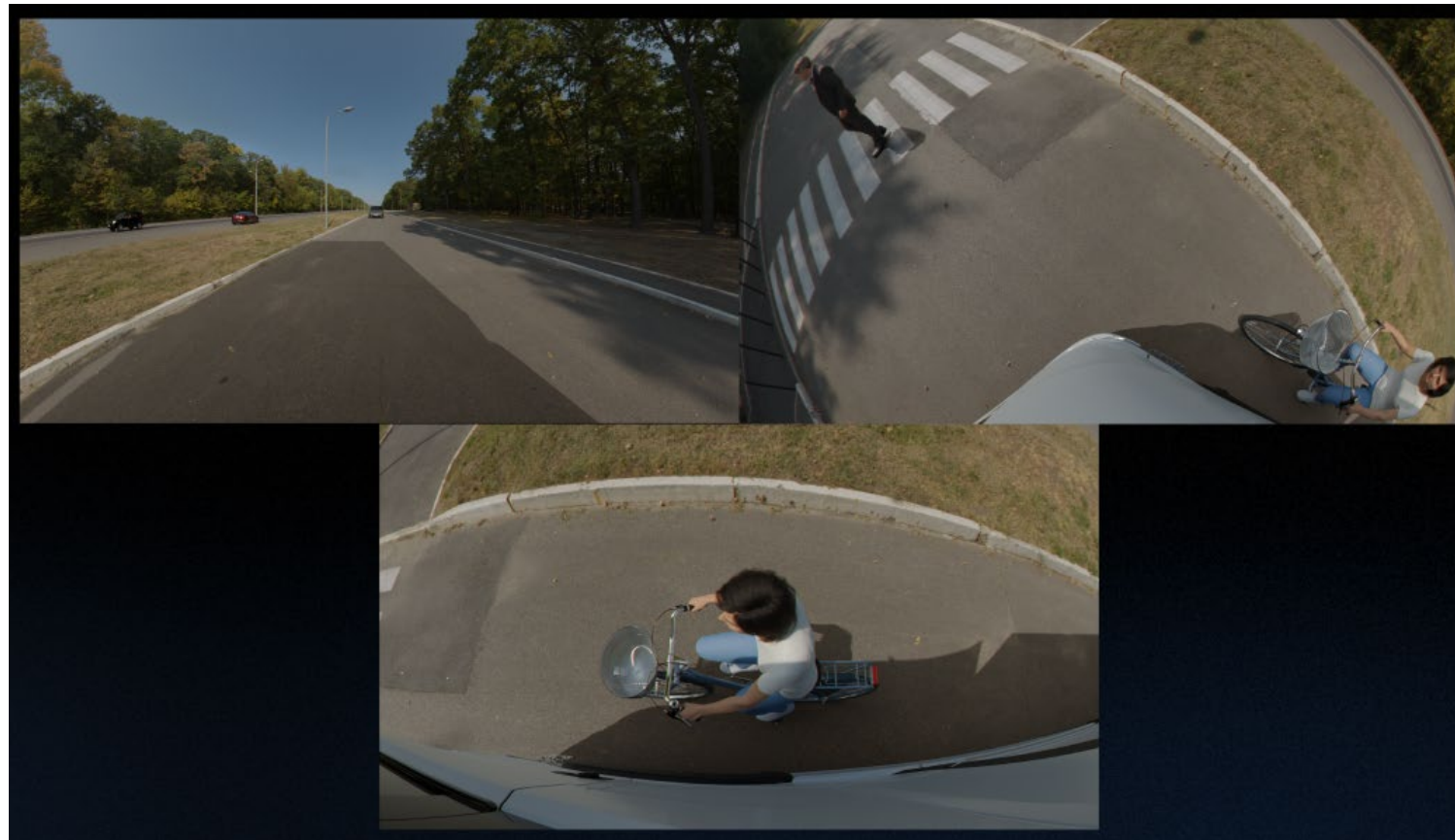



TILKOBLINGSGRENSESNITT FOR PÅBYGGERE

- Tilkoblingsgrensesnittet for kameraene er plassert i DDU-kontrollenheten
- DDU er plassert på passasjersiden bak den sentrale elektriske enheten (P2)

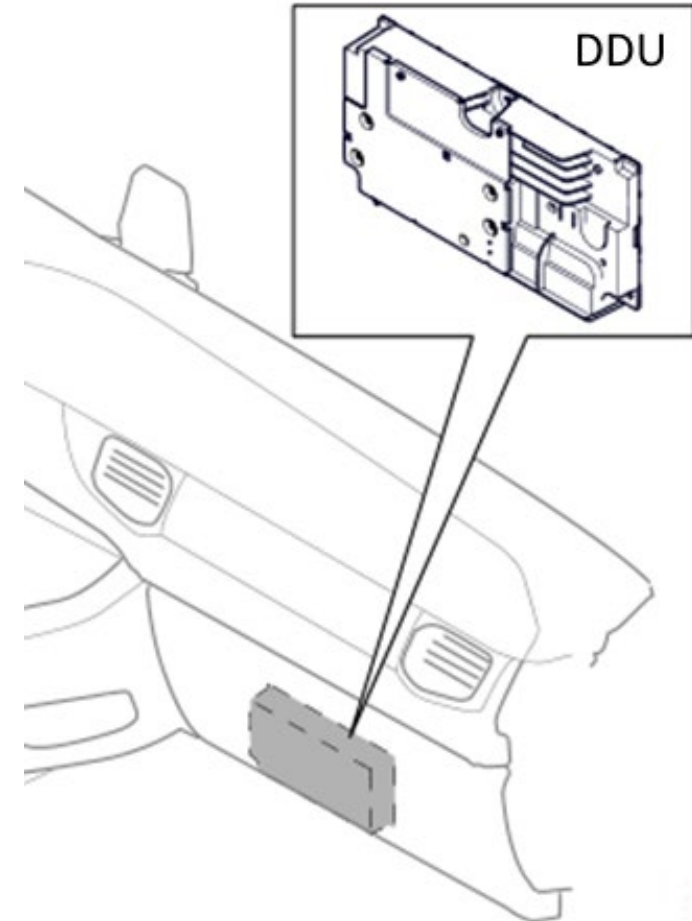



ANALOG KAMERA PORTER 1 - 3

- Støttede videosignalformater: AHD, PAL og NTSC
- Signalformat kan endres med Scania serviceverktøy (SWS) – ingen brukerinnstilling i Smart Dash
- CAM2 og CAM3 deler en kontakt på grunn av fysiske begrensninger i DDU-kontrollenhetens maskinvare

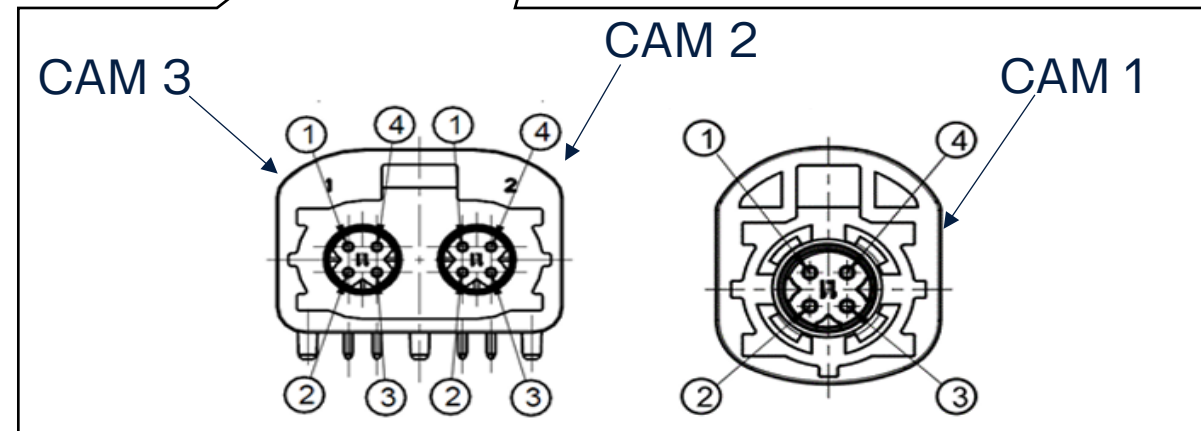
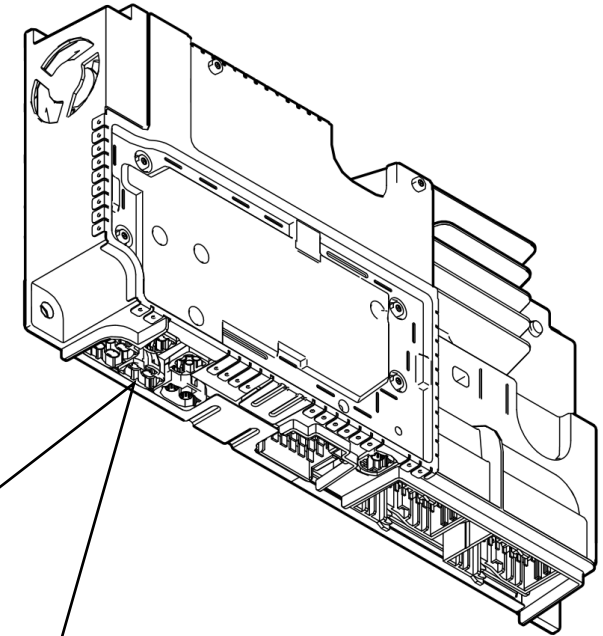



UTGANGER FOR KAMERATILBEHØR

- Grensesnitt til kamerautganger ved DDU ECU-kontakt A (stikker 31 – 33)
- 3 x utganger (+ 24 V) for forsyning av kameratilbehør, som kameravisirer når respektive kameraport er aktivert
- Maks. utgangsstrøm 500 mA

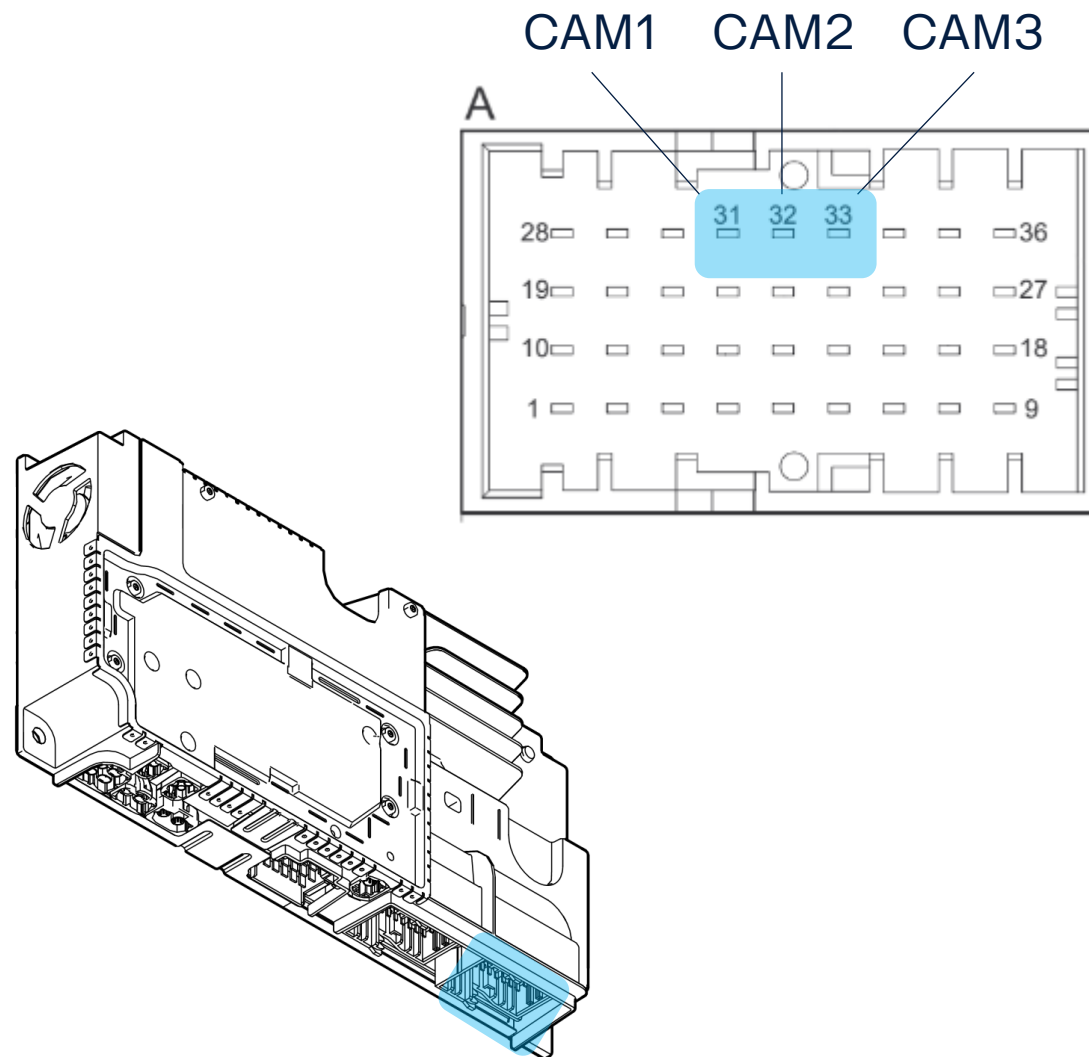



KAMERAAKTIVERING - NÅVÆRENDE STATUS

SCANIA



AKTIVERING AV KAMERA

- **Ryggekamera**

- automatisk aktivering når revers er lagt inn
- manuell aktivering

- **Frontkamera**

- automatisk aktivering i kjøretøyets hastighetsområde 0-30 km/t (forover / parkeringsbrems ikke aktivert)
- manuell aktivering

- **Generelt kamera**

- aktivering med direkte inngangssignal fra påbygg
- manuell aktivering

Analogt

Digitalt



AKTIVERING AV KAMERA

- Ikke mulig å stille inn automatiske aktiveringsbetingelser som med analogt dashboard

Camera view			
Camera 1	Rear view camera	Rear view camera	✓
Deactivate camera 1 at speed limit	250	*250	
Activate camera 1 when the right-hand direction indicator is active	Off	*Off	
Activate camera 1 when work light is active	Off	*Off	
Camera 2	General camera	General camera	✓
Deactivate camera 2 at speed limit	250	*250	
Activate camera 2 when the left-hand direction indicator is active	Off	*Off	
Activate camera 2 when work light is active	Off	*Off	
Exposure level in camera view, camera 1	125	*125	
Exposure level in camera view, camera 2	125	*125	



KAMERAAKTIVERING – NYE FUNKSJONER

SCANIA



M1	EG1
ED1	EG2

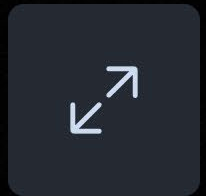

- 24.0 °C +



AUTO



- 5 +



EXTERN KAMERAAKTIVERING VIA BCI

- Planlagt introduksjon november 24
- Krever BCI-funksjonalitet, FPC 5837A
- Aktivering av alle kameraporter via BICT-logikk eller ekstern CAN
- Mulig å ettermontere funksjonalitet med programvareoppdatering til kjøretøy med tidligere produksjon



KAMERAAKTIVERING VIA BCI – EKSEMPEL

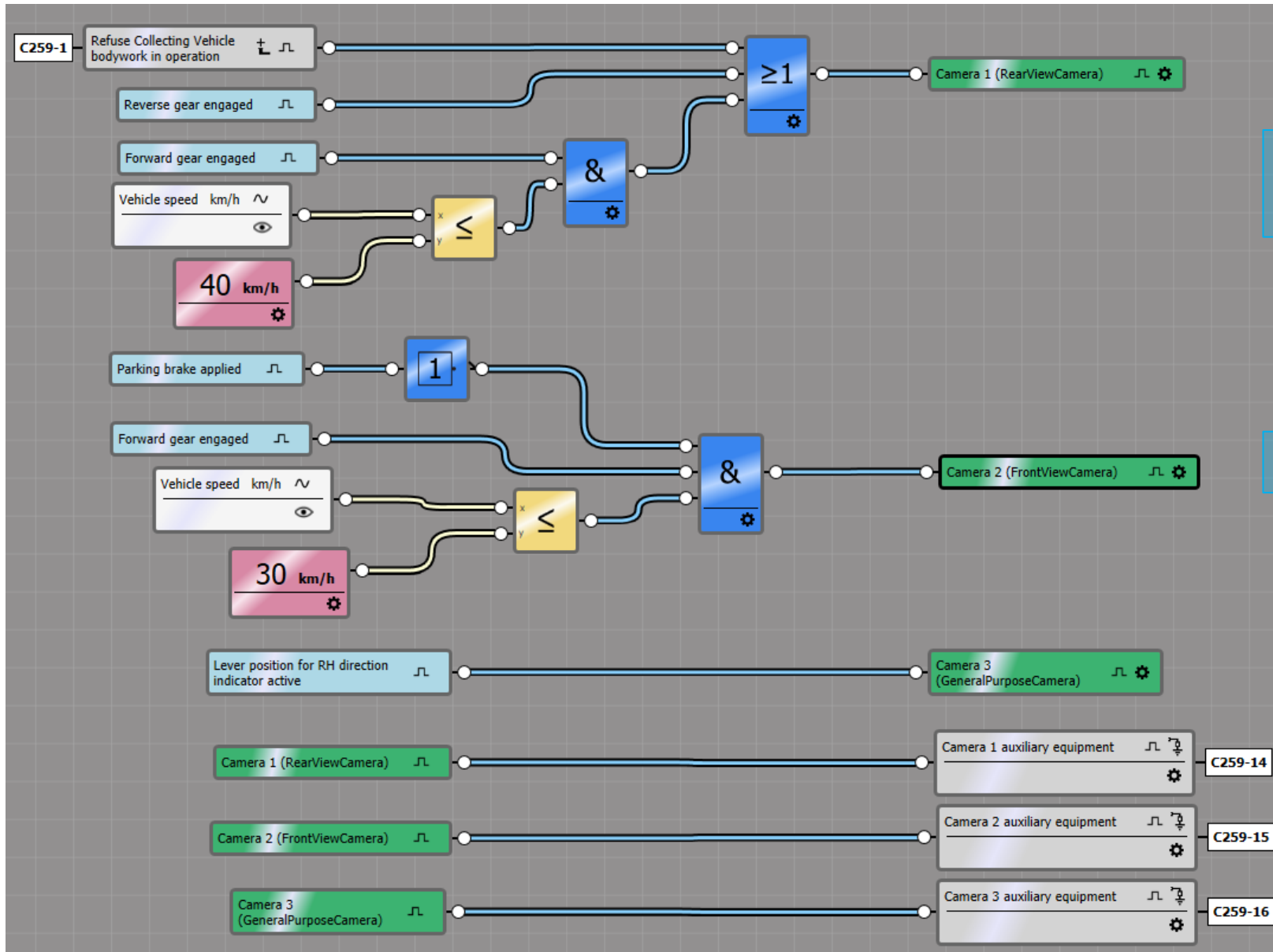

Søppelbiler EN1501-1
Ryggekamera

Frontkamera

Blindsonkamera

Utganger til
kamera tilbehør



M1



24.0 °C



AUTO



5



Automatisk aktivering (revers) + manuell aktivering + ekstern aktivering via BCI (nov. 24)

Manuell aktivering + ekstern aktivering via BCI (nov. 24)

Manuell aktivering + ekstern aktivering via BCI (nov. 24)

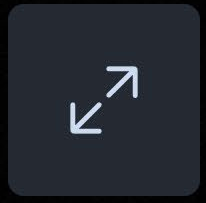
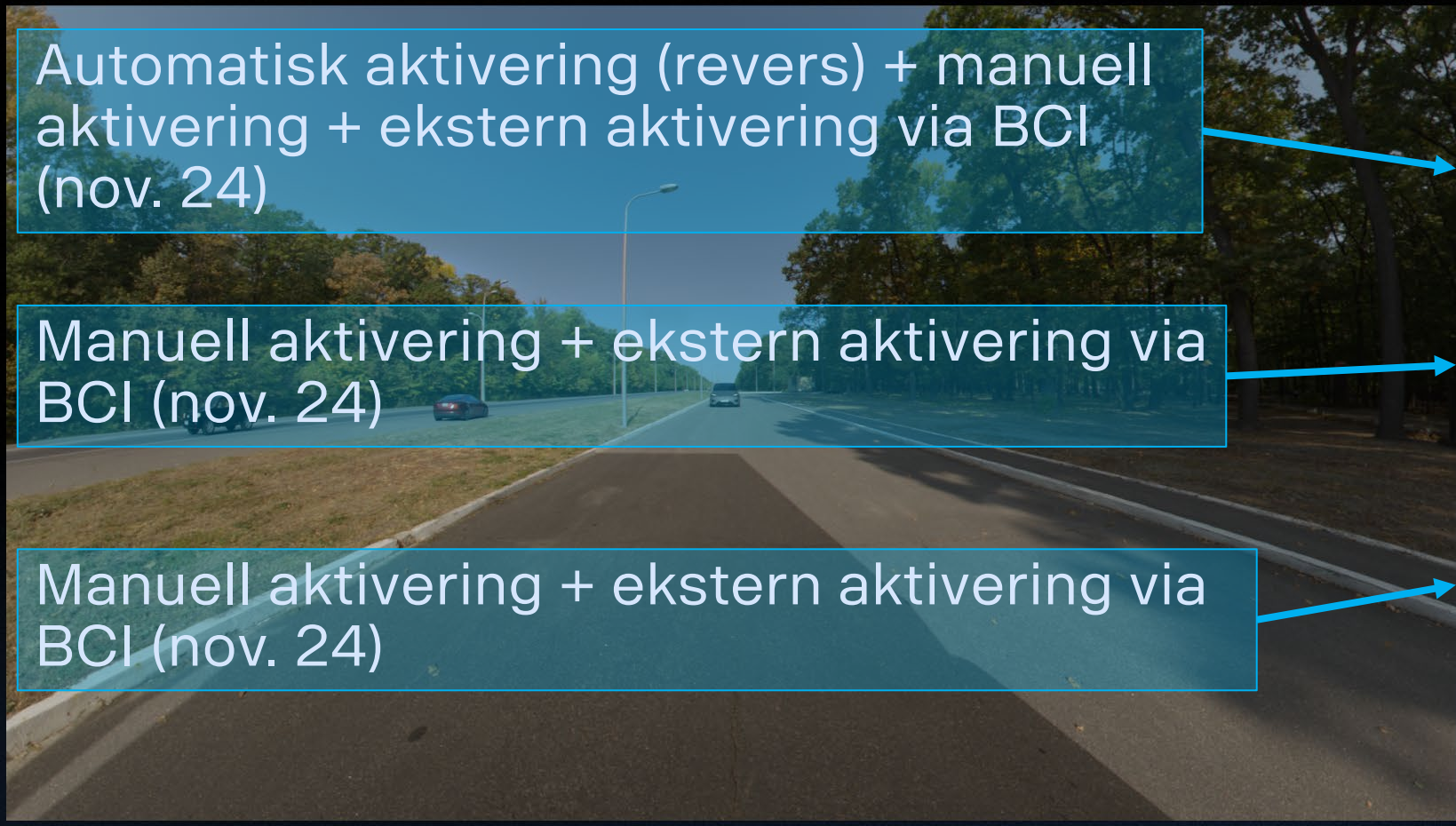



KAMERAFORBEREDELSE OG TILBEHØR

SCANIA



FIT FOR USE (FFU)

- FFU-kameraforberedelser, variantkodefamilie 3832xx, vil bli konvertert til 11104xx i digitalt dashboard
- Introduksjon forsinket på grunn av stor avhengighet av ekstern kameraaktivering (nov. 24)



SCANIA TILBEHØR

- Scania-tilbehør gir et bredt utvalg av kameraer, ledningsnett og svitsjegrensesnitt for Smart Dash

ACCESSORIES CAMERAS AHD SMART DASH



AHD Compact camera	
R/N	View angle
3100030	60(H) / 35(V) / 69(D)
3100028	118(H) / 67(V) / 137(D)
3188881	154(H) / 87(V) / 177 (D)

AHD IR Shutter Camera	
R/N	View angle
3100029	125(H) / 66(V) / 142(D)

AHD IR Camera	
R/N	View angle
3100025	118(H) / 67(V) / 137(D)

AHD VRUD Camera	
R/N	View angle
3022020	190(H) / 124(V) / 232(D)
3025400	Plastic cover

AHD = Analog High Definition VRUD = Vulnerable Road User D

ACCESSORIES CABLES AHD SMART DASH

Adapters

Lengths	Partnumber
3 meter	2823099
5 meter	2823100
7 meter	2823101
10 meter	2823102
12 meter	2823103
15 meter	2823104
18 meter	2823105
24 meter	2823106
2 meter ADR Approved	3100055
5 meter ADR Approved	3100056
7 meter ADR Approved	3180717
10 meter ADR Approved	3180718
15 meter ADR Approved	3100057
20 meter ADR Approved	3100058
25 meter ADR Approved	3100060

Trailer ODU adapter R/N 3100070
 Needed in all additional camera installations, with the dual camera input on the smart dash premium, into the single input.







Camera adapter R/N 3000075
 USB to (1) adapter and trailer cables to the VRUD camera cable

Single ODU adapter R/N 3000081
 Connect AHD cameras to Camera input 1 on the smart dash.

Camera adapter R/N 3000075
 If you want to fit VRUD camera to trailer

Shutter camera adapter R/N 3103400
 Connect trigger wire to ECU track or receive signal from an axle

TRAILER CABLES

3100004	Trailer cable, auto detect if trailer cam is connected	
3180035	Trailer cable, auto detect if trailer camera is connected, with built in connector CAN-HD signal for trailers with older camera systems	
3100001	Trailer camera with 1 camera ADR approved	
3100002	Trailer camera with 2 camera ADR approved	
3100003	Trailer camera with 3 camera ADR approved	
3100005	Trailer cable with 1 camera	
3100003	Trailer cable with 2 camera	

3100003 Trailer cable with ODU adapter



TILBEHØR TILHENGERKABEL EKSEMPEL

Chassis VRUD connector

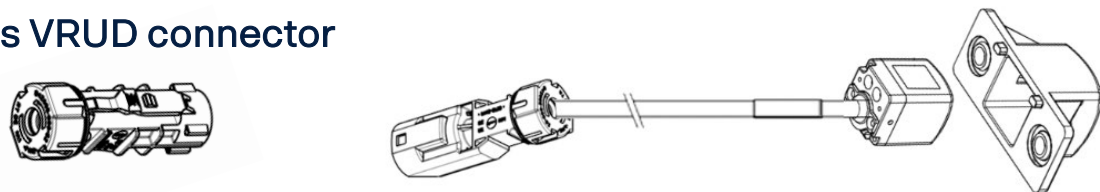

Chassis VRUD connector

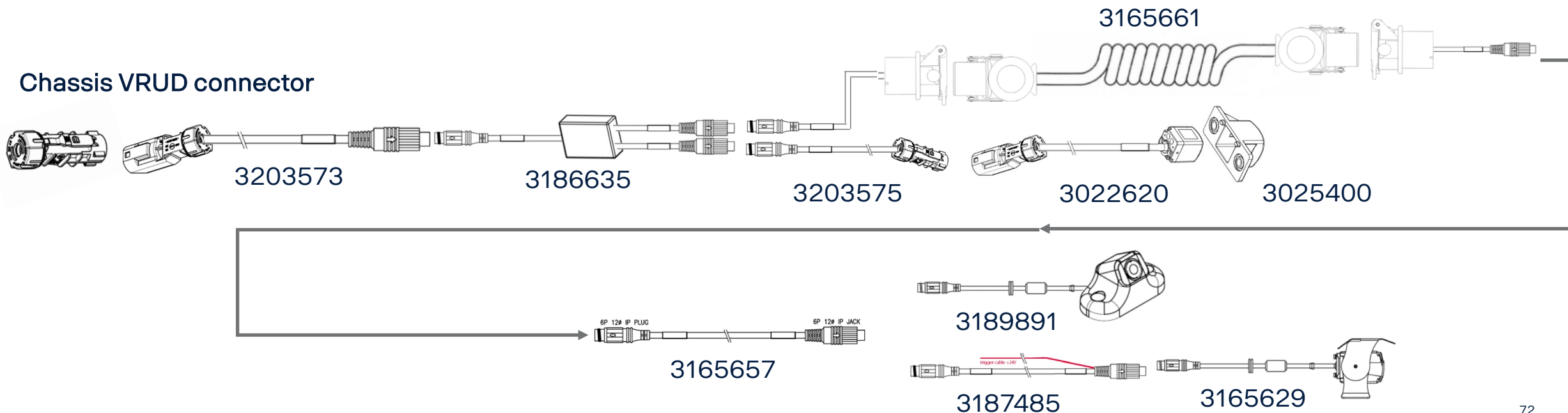

TILBEHØR ADAPTERE / KABLER



"A" ROSENBERGER 4P PLUG(M) Scania pn. 3203573 "chassis adapter" "B" 6P 12φ IP JACK

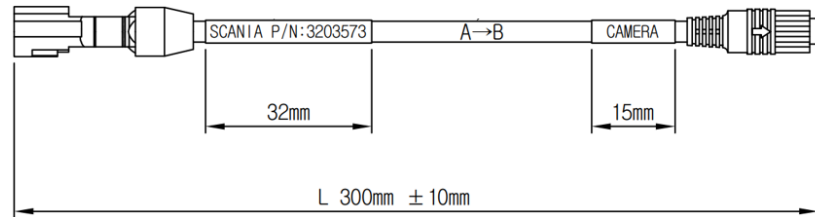

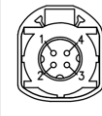
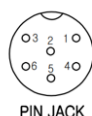
"A"	"A"	WIRE COLOR	CONNECTION	"B"	"B"
 PIN PLUG FRONT VIEW	"A" 1	BROWN	VIDEO GND	"B" 4	 PIN JACK FRONT VIEW
	"A" 2	GREEN	POWER GND	"B" 6	
	"A" 3	ORANGE	VIDEO	"B" 3	
	"A" 4	BLUE	POWER	"B" 1	

"A" ROSENBERGER 4P JACK(F) Scania pn. 3203561 "DDU single adapter" "B" 6P 12φ IP JACK

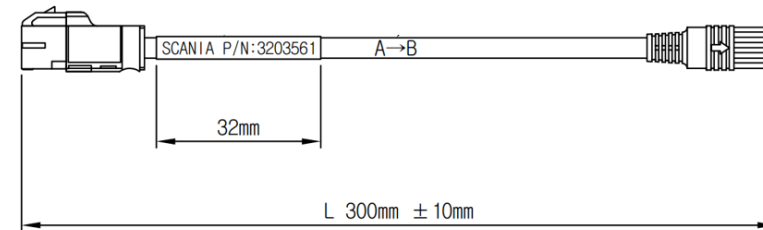

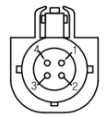
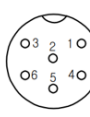
"A"	"A"	WIRE COLOR	CONNECTION	"B"	"B"
 PIN JACK FRONT VIEW	"A" 1	BLUE	POWER	"B" 1	 PIN JACK FRONT VIEW
	"A" 2	ORANGE	VIDEO	"B" 3	
	"A" 3	GREEN	POWER GND	"B" 6	
	"A" 4	BROWN	VIDEO GND	"B" 4	

"A" ROSENBERGER 4P JACK(F) Scania pn. 3203575 "VRUD camera adapter" "B" 6P 12φ IP PLUG

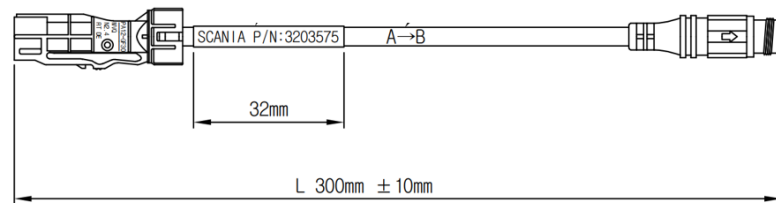

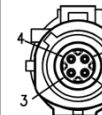
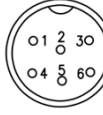
"A"	"A"	WIRE COLOR	CONNECTION	"B"	"B"
 PIN JACK FRONT VIEW	"A" 1	BLUE	VIDEO GND	"B" 4	 PIN PLUG FRONT VIEW
	"A" 2	ORANGE	POWER GND	"B" 6	
	"A" 3	GREEN	VIDEO	"B" 3	
	"A" 4	BROWN	POWER	"B" 1	

"A" 6P 12φ IP PLUG Scania pn. 3186717 "7m ADR cable" "B" 6P 12φ IP JACK

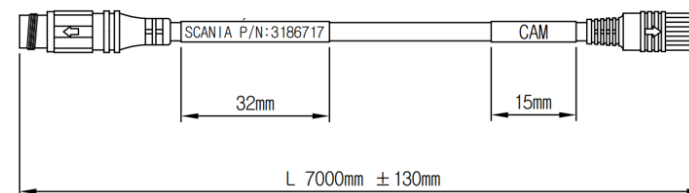

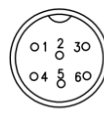
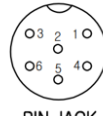
"A"	"A"	WIRE COLOR	CONNECTION	"B"	"B"
 PIN PLUG FRONT VIEW	"A" 1	REC	CAM B+	"B" 1	 PIN JACK FRONT VIEW
	"A" 2	BLUE	CONNECTED	"B" 2	
	"A" 3	YELLOW	CAM VIDEO	"B" 3	
	"A" 4	WHITE	VIDEO GROUND	"B" 4	
	"A" 5	GREEN	CONNECTED	"B" 5	
	"A" 6	BLACK (TUBE)	BRAID SHIELD POWER GND	"B" 6	



RYGGEDETEKSJONSKAMERA (UNECE R158)

SCANIA



RYGGEDETEKSJONSKAMERA

- Deteksjon av myk trafikant bak kjøretøyet, med : FPC 9631A
- Videosignalformat AHD (Analog High Definition)
- Plassering fra fabrikk avhenger av chassiskonfigurasjon
- FPC 10080A Forlengelseskabel for ryggekamera (lengde 7,5 m)

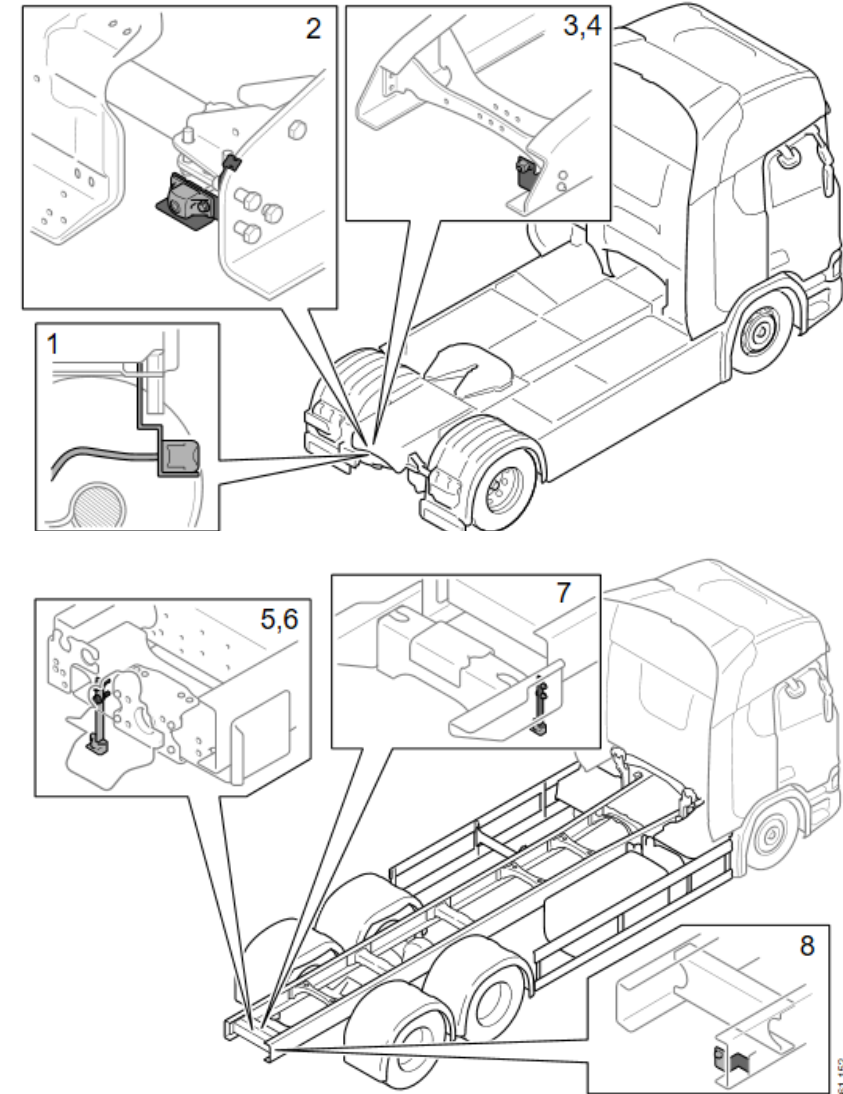
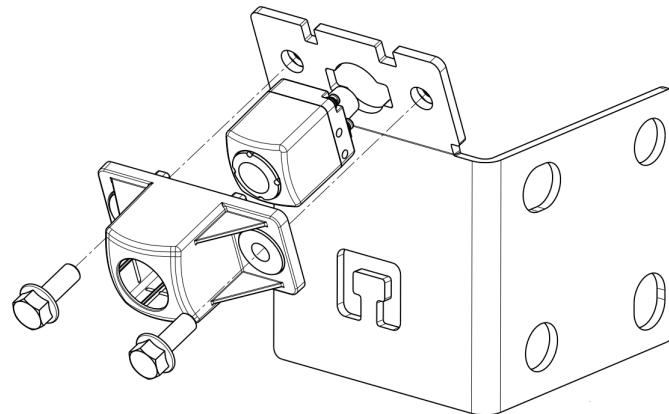



RYGGEDETEKSJONSKAMERA (UNECE R158)

- Ryggedeteksjonskamera (pn. 3022620) er ikke utstyrt med kameralinsebeskyttelse
- Mulig eksponering for skitt og snø
- Lokal ny sertifisering kreves hvis den erstattes med et lukkerkamera

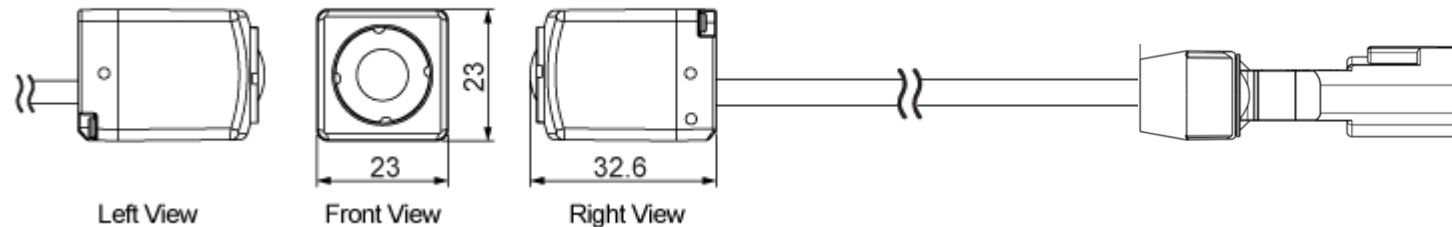



POSISJON AV RYGGGEKAMERA

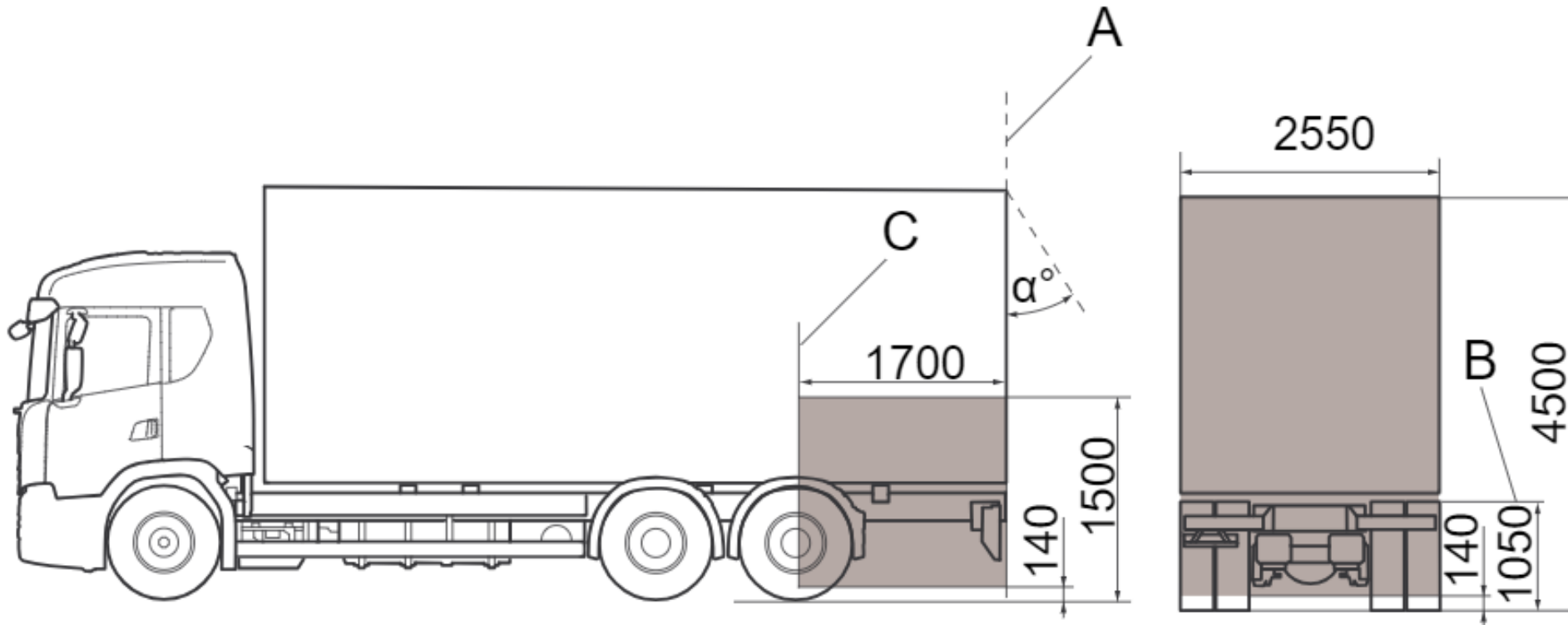

Camera angle (α°)	Camera height (mm)
35	4 001-4 500
40	3 501-4 000
45	3 001-3 500
50	2 501-3 000
55	2 001-2 500
60	1 501-2 000
70	1 051-1 500
70-90	140-1 050

- A. Bakerste punkt på kjøretøyet (inkl. påbygg)
- B. Kameraet må vinkles over oppgitt nivå for å opprettholde riktig synsfelt
- C. Fremste punkt for kameraposisjon

POSISJON AV RYGGKAMERA

Close-proximity rear-view field of vision

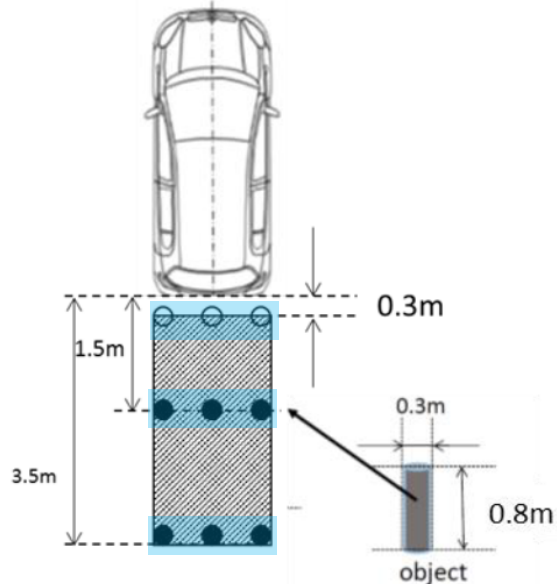

UNECE R158

15.2.1. Requirements

When tested under the conditions defined in Annex 9 the requirement for close-proximity rear-view field of vision shall be considered to be satisfied if the defined field of vision can be seen:

- (a) For the test objects in the **first row** (Test objects A, B, and C):
A 0.15 m x 0.15 m area or the top of the test object shall be visible at least one position on each test object.
- (b) For the test objects in the **second row** (Test objects D, E, and F) and the **third row** (Test objects G, H, and I):
The whole test object shall be seen.

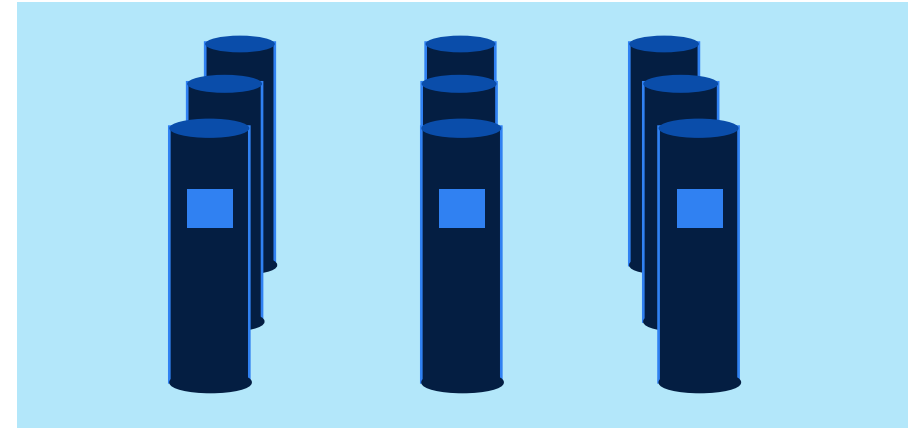

Illustrasjon på akseptabel ryggkameravising av UNECE R158-testobjektene



RYGGEDETEKSTJONSKAMERA (UNECE R158)

- Koblet til DDU analog kamera port 3 (CAM3) i DDU Advanced
- Plasthus må fjernes fra adapterkabel pn. 3203561 for å koble tilleggskamera til CAM2-port i dobbel kontakt

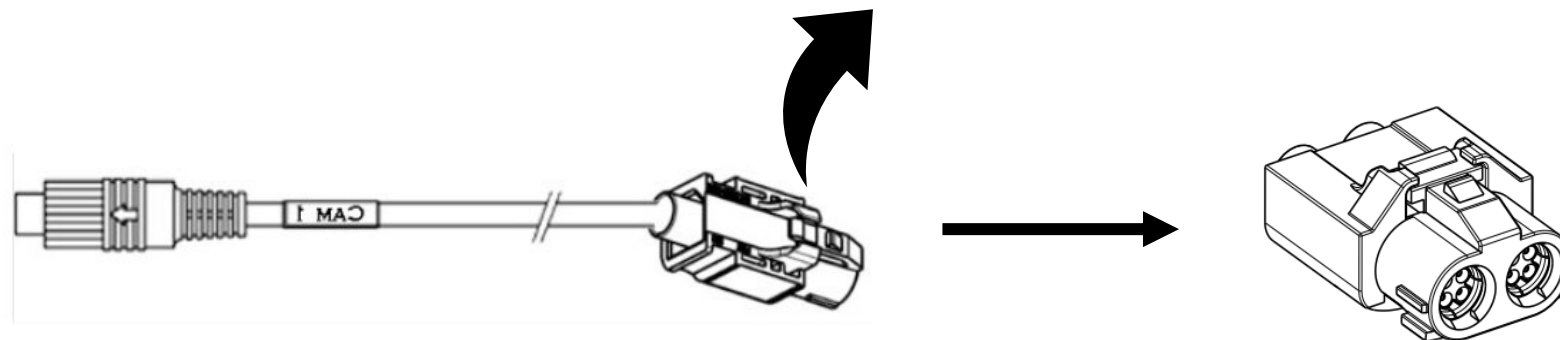
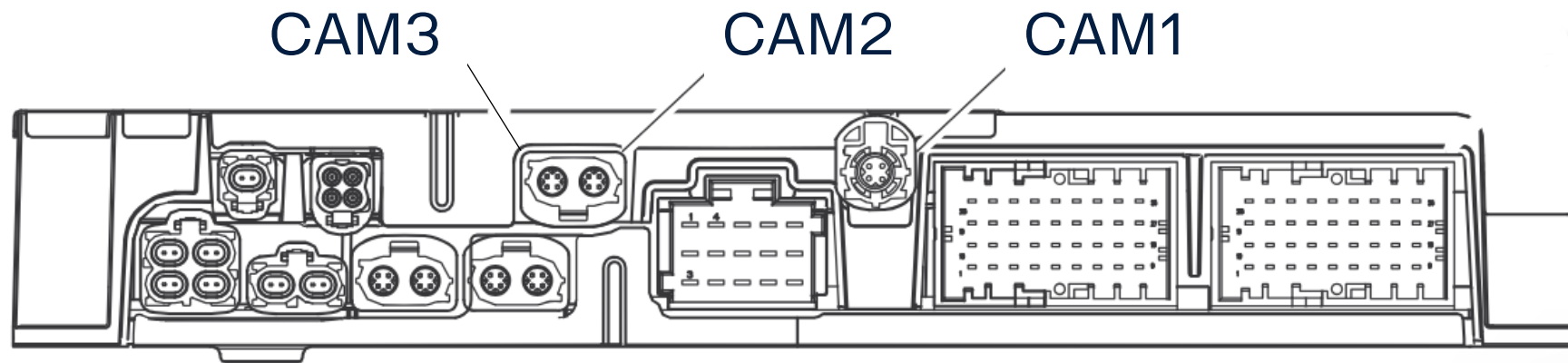



RYGGEKAMERA MED TILHENGER

- Tilhengere omfattes ikke av UNECE R158 - ingen begrensninger er satt på tilhengerens ryggekamerainstallasjon eller maskinvare
- Automatisk bytte til ryggekamera på tilhenger er tillatt
- Med eksternt grensesnitt for svitsj/prioritering (Scania-tilbehør)
- Scania-tilbehør gir et svitsjegrensesnitt som konverterer videosignal fra formater med lavere oppløsning til AHD

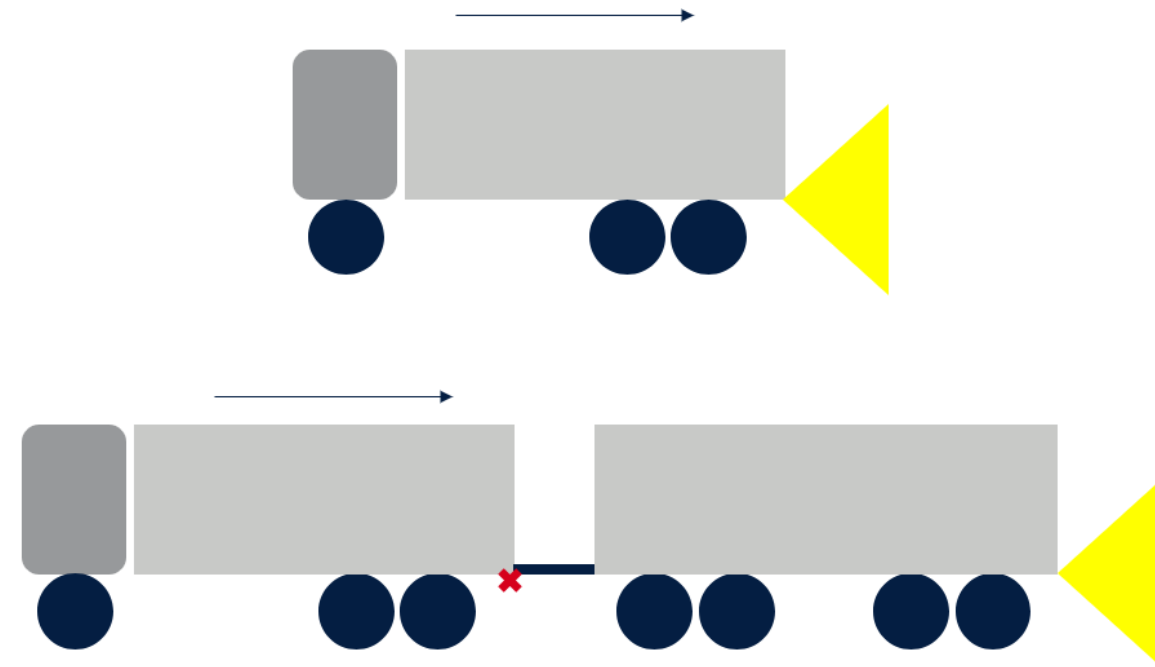



RADAR

SCANIA



FRONT RADAR

- UNECE R159 – *Moving off information system (MOIS)*
- *Advarsel om kollisjon av myke trafikanter, foran, med: FPC 9105A*
- Et system for å oppdage myk trafikanter foran kjøretøyet og advare føreren om risikoen for kollisjon
- Radarens synsfelt må ikke blokkeres
- Radaren kan ikke tildekkes eller lakkeres

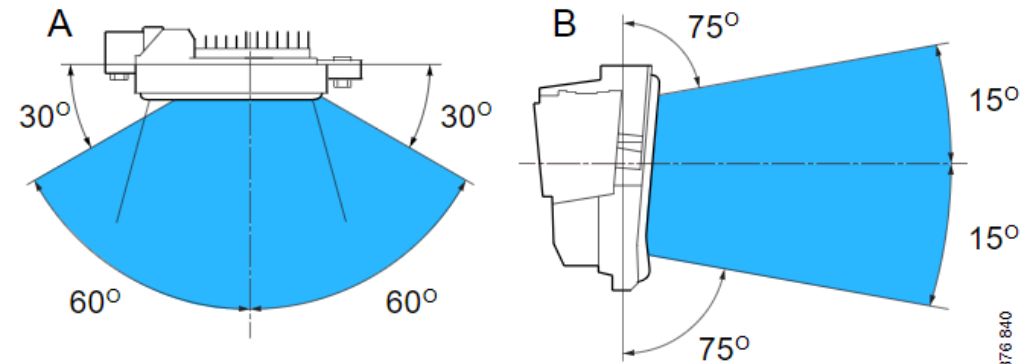
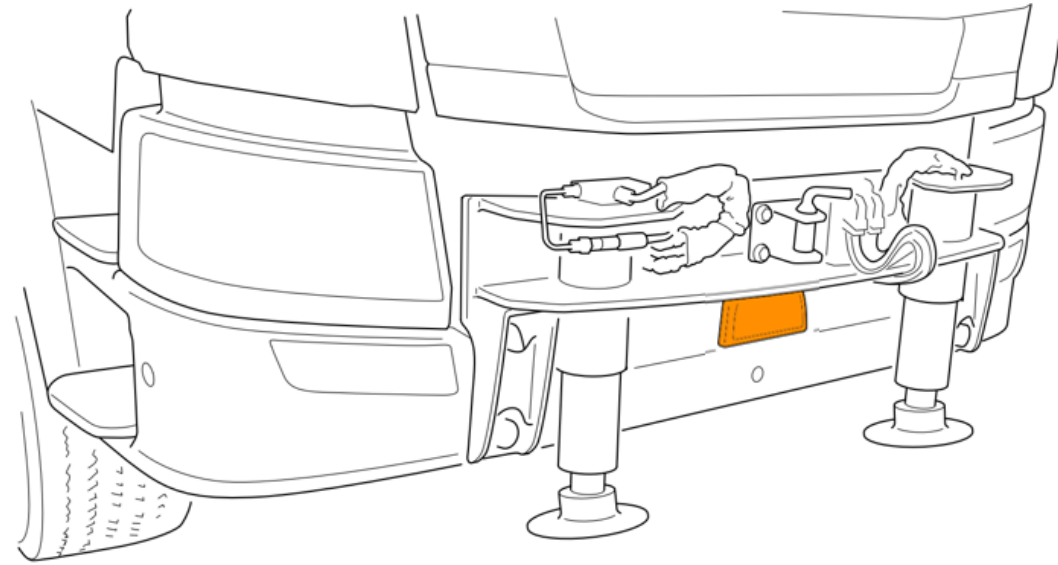

FRONT RADAR



Flytting av frontradaren innenfor forhåndsdefinerte grenser er dekket av fabrikksertifikatet siden produksjonsperiode 23.06

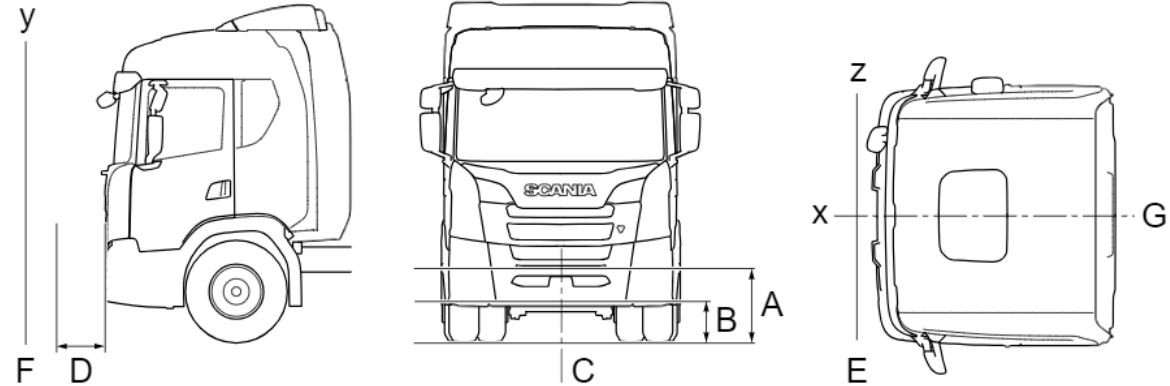

Pos.	Radar		Description
	DIS2	DIS3	
A	860 mm	1,000 mm	Longest permitted distance from the ground surface to the centre of the radar's field of view
B	350 mm	295 mm	Shortest permitted distance from the ground surface to the centre of the radar's field of view
C	10 mm	10 mm	Longest permitted distance from the centreline of the truck to the centre of the radar unit
D	500 mm	500 mm	Longest permitted distance in the longitudinal direction of the vehicle in front of factory position 500 mm measured to the front of the radar unit
E	$\pm 1,0^\circ$	$\pm 6^\circ$	Maximum permitted angle in the Z-axis from the horizontal plane
F	$\pm 0,1^\circ$	$\pm 6^\circ$	Maximum permitted angle in the Y-axis from a factory position
G	$\pm 1.5^\circ$	$\pm 5^\circ$	The maximum permitted angle in the X-axis from the horizontal plane



SIDE RADAR

- UNECE R151 – *Blindsonerinformasjonssystem (BSIS)*
- *Varsel om kollisjon med myke trafikanter, side:* FPC 9824 A/B (LHS/RHS)
- Et system for å advare føreren om trafikanter i i kjøretøyets blindsoner
- Radarene påvirkes ikke hvis kjøretøyets bredde holdes under 2,6 m
- Radarer må ikke flyttes, tildekkes eller lakkeres

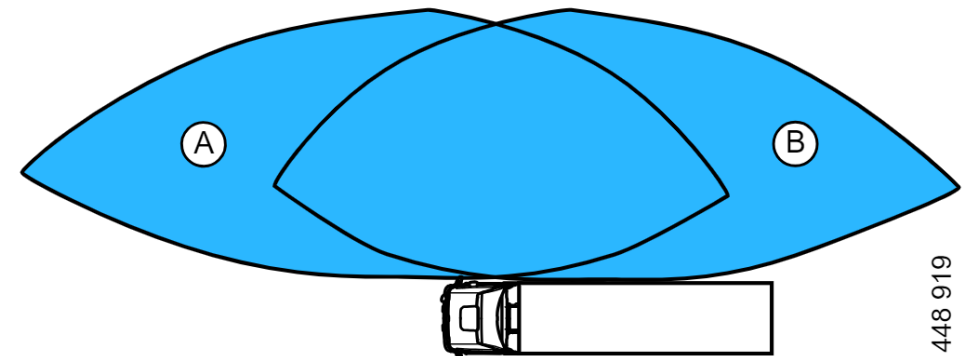
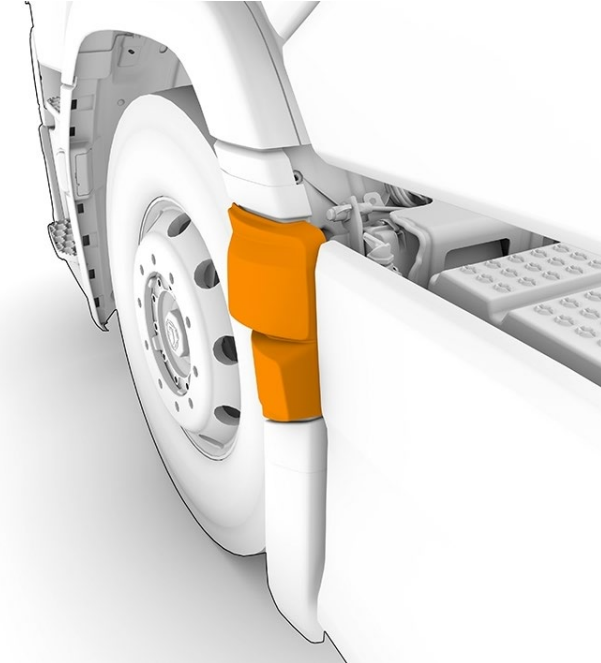



DEKKTRYKKOVERVÅKINGS SYSTEM

SCANIA



GENERELT

- UNECE R141 – *Tyre Pressure Monitoring System (TPMS)*
- FPC3549A : *Overvåking av dekktrykk, med*
- Hovedformålet: informere føreren hvis ett eller flere dekk har under- eller overtrykk
- Varsler om over- og undertrykk utløses basert på referansetrykkverdien som er angitt av føreren for hver aksel via Smart Dash
- Tilhenger-TPM støttes også



TPM PÅ LASTEBILCHASSIS

SCANIA

FØRERINFORMASJON



NB!

Varsel på lastebilchassis styres av
akselkonfigurasjon i SOPS

Tyre Pressure



- A. Visualization of vehicle model
- B. Normal tyre pressure
- C. Selected tyre
- D. No data available state
- E. Critical tyre pressure
- F. Low tyre pressure
- G. Low tyre pressure with leakage indicator "!"

[kPa]



FØRERINFORMASJON

 **High tyre pressure**
Check at next stop

↶ TPM reference pressure

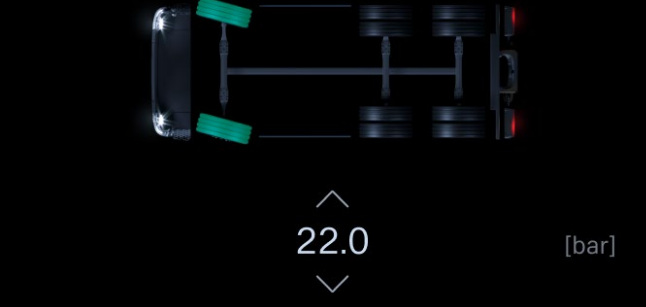

22.0 [bar]

 **Insufficient tyre pressure**
Check at next stop

 **Tyre air leak**
Drive to nearest workshop

 **Low tyre pressure**
Check at next stop

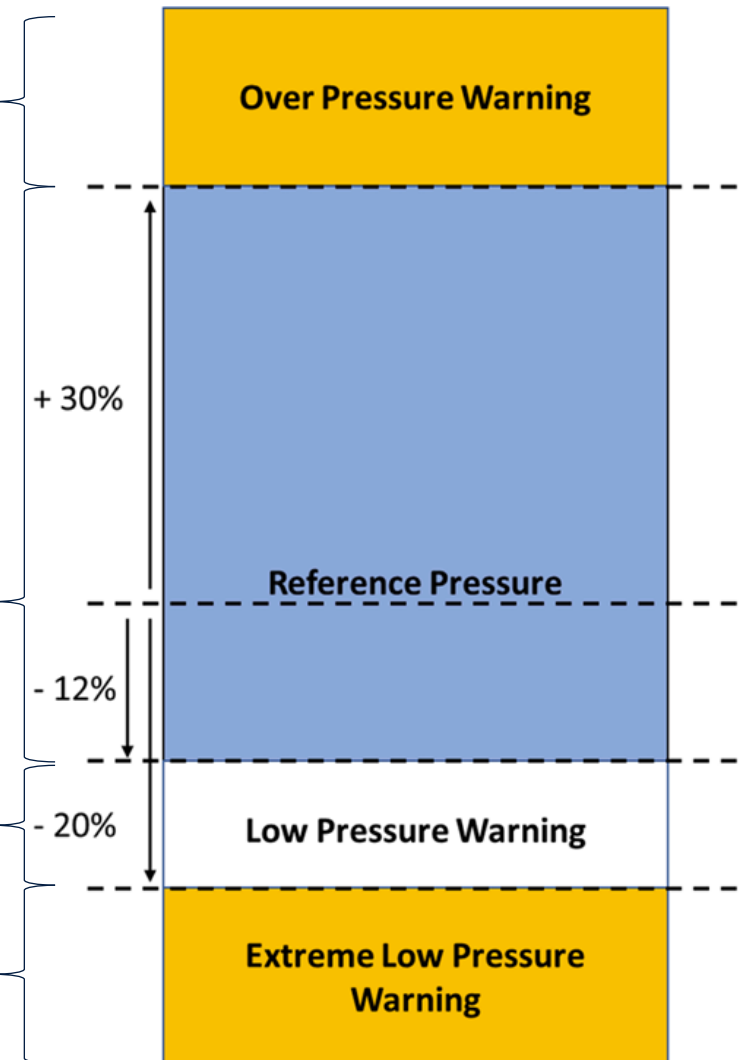

Varsel om dekklekkasje vises i tilfelle en rask reduksjon i dekktrykket oppdages med lekkasjerate på 75 mbar per minutt eller mer.



TPM-SYSTEMOPPSETT

- Eksempel: 6x4 akselkonfigurasjon

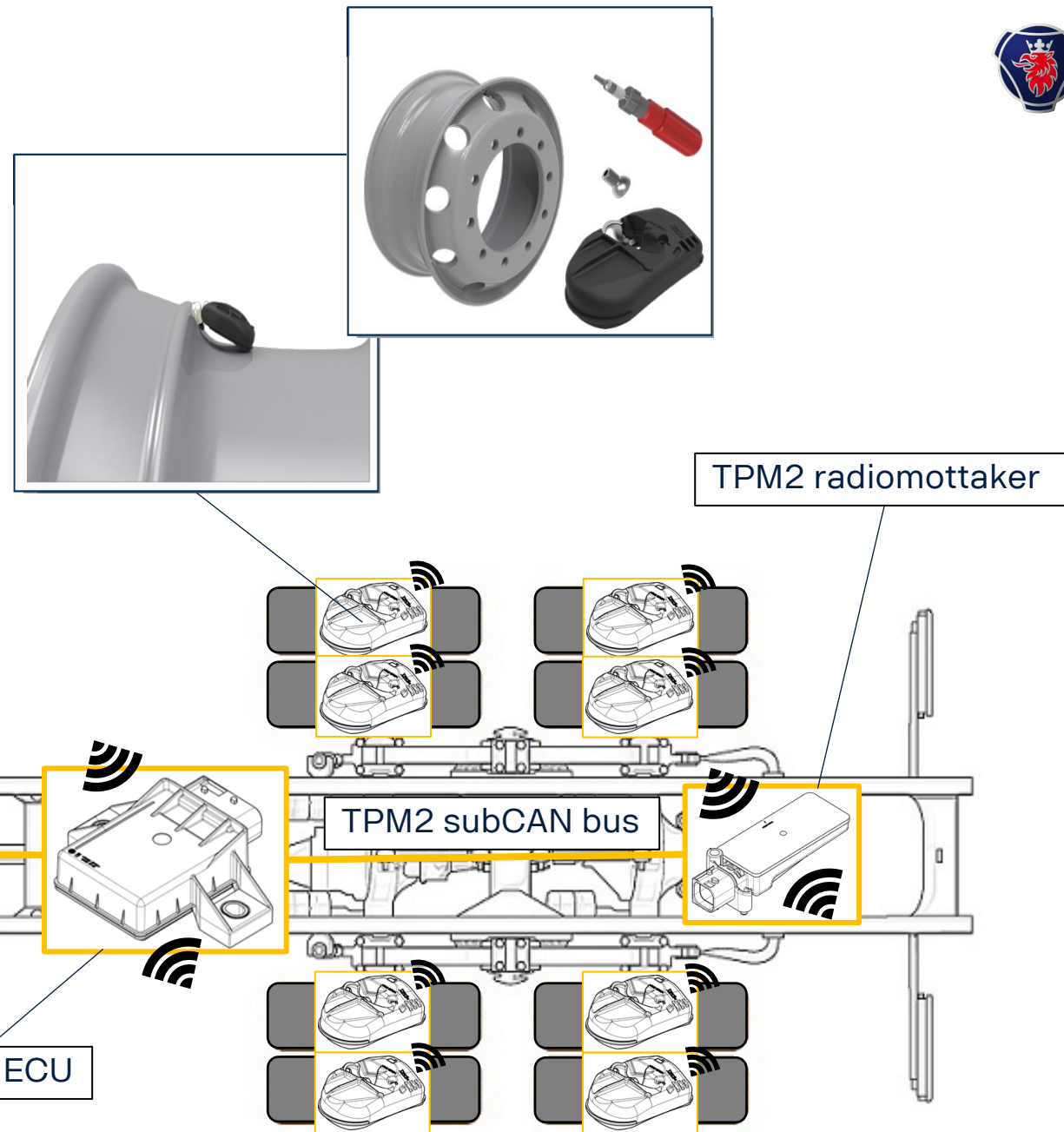



FØRERINFORMASJON

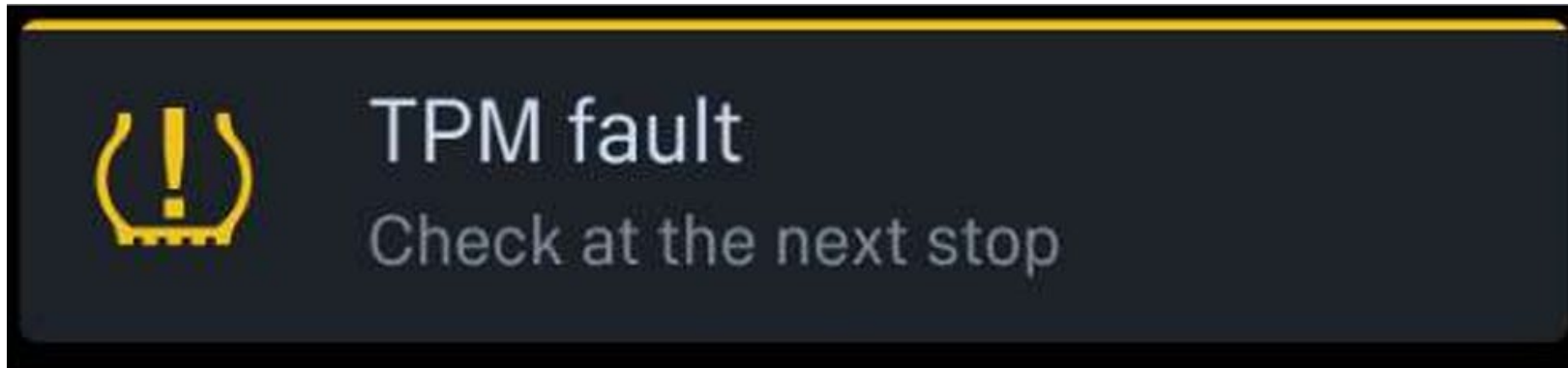

Eksempel på TPM-feil:

TPM2 ECU mottar ingen overføring fra en eller flere sensorer innen 10 minutter med kjøretøyets hastighet over 25 km / t.



REGISTRERING AV DEKKTRYKKSSENSOR

- Dekksensor-ID-er registrert i TPM2 ECU-minne for hver hjulposisjon
- En ny registrering kreves hvis:
 - Sensor er byttet
 - Sensorenes posisjoner endret seg
- Sensorregistrering kan utføres av:
 - Teknikere på Scania-verksted/påbygger med Scanias ettermarkedsverktøy, SWS
 - Sjåfør / vanlig dekkverksted via førerdisplay



REGISTRERING AV DEKKTRYKKSSENSOR

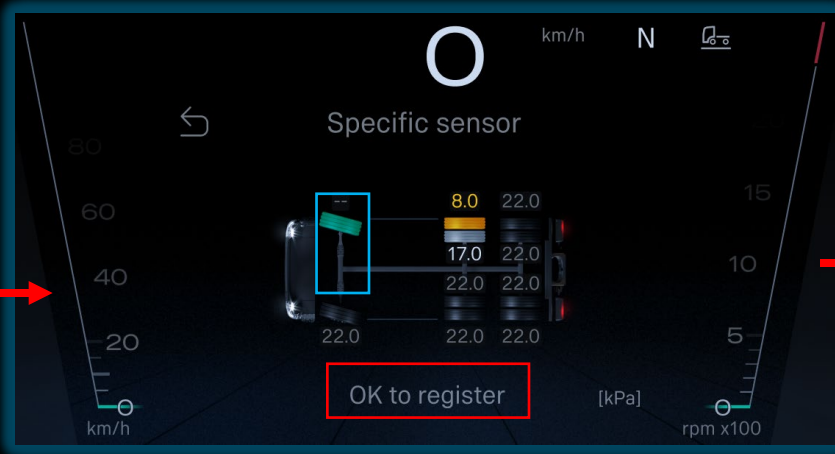
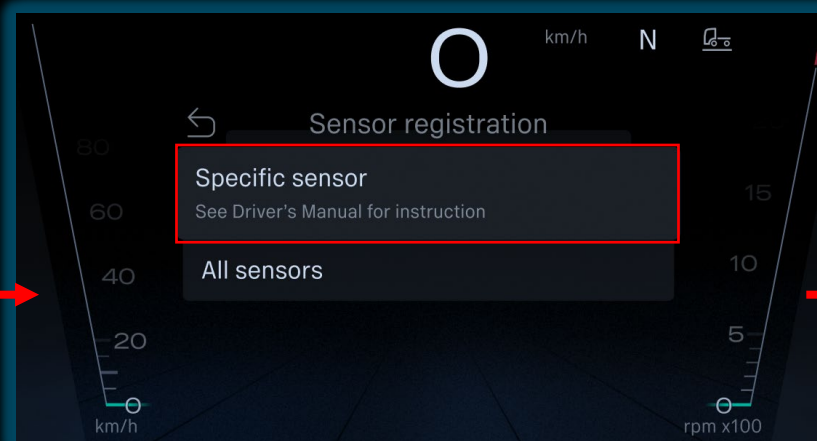
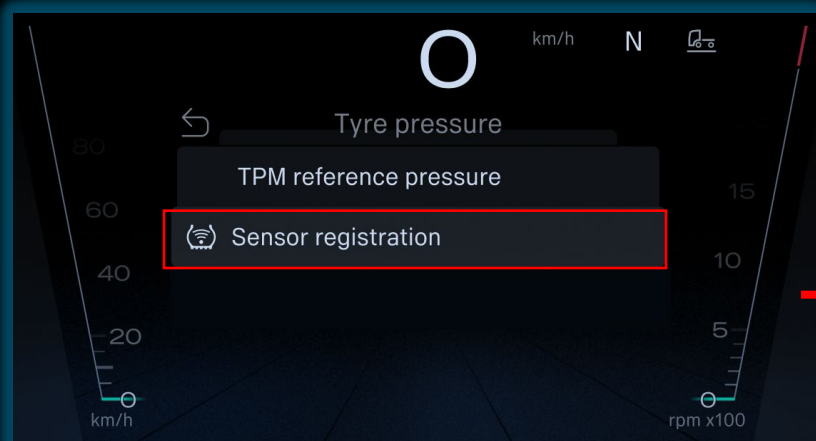



REGISTRERING AV DEKKTRYKKSSENSOR

Use LF tool



or

Release 0,25 bar



Driver exits cab

The driver parks the truck and leaves the cab and walks to the tyre

Complete

5 seconds wait ECU check with other sensor to prevent error

Blinkers flash
6x times



Feedback to the driver of the completion

Driver enters cab

The driver re-enters the cab to continue driving or register a new sensor.



REGISTRERING AV DEKKTRYKKSSENSOR

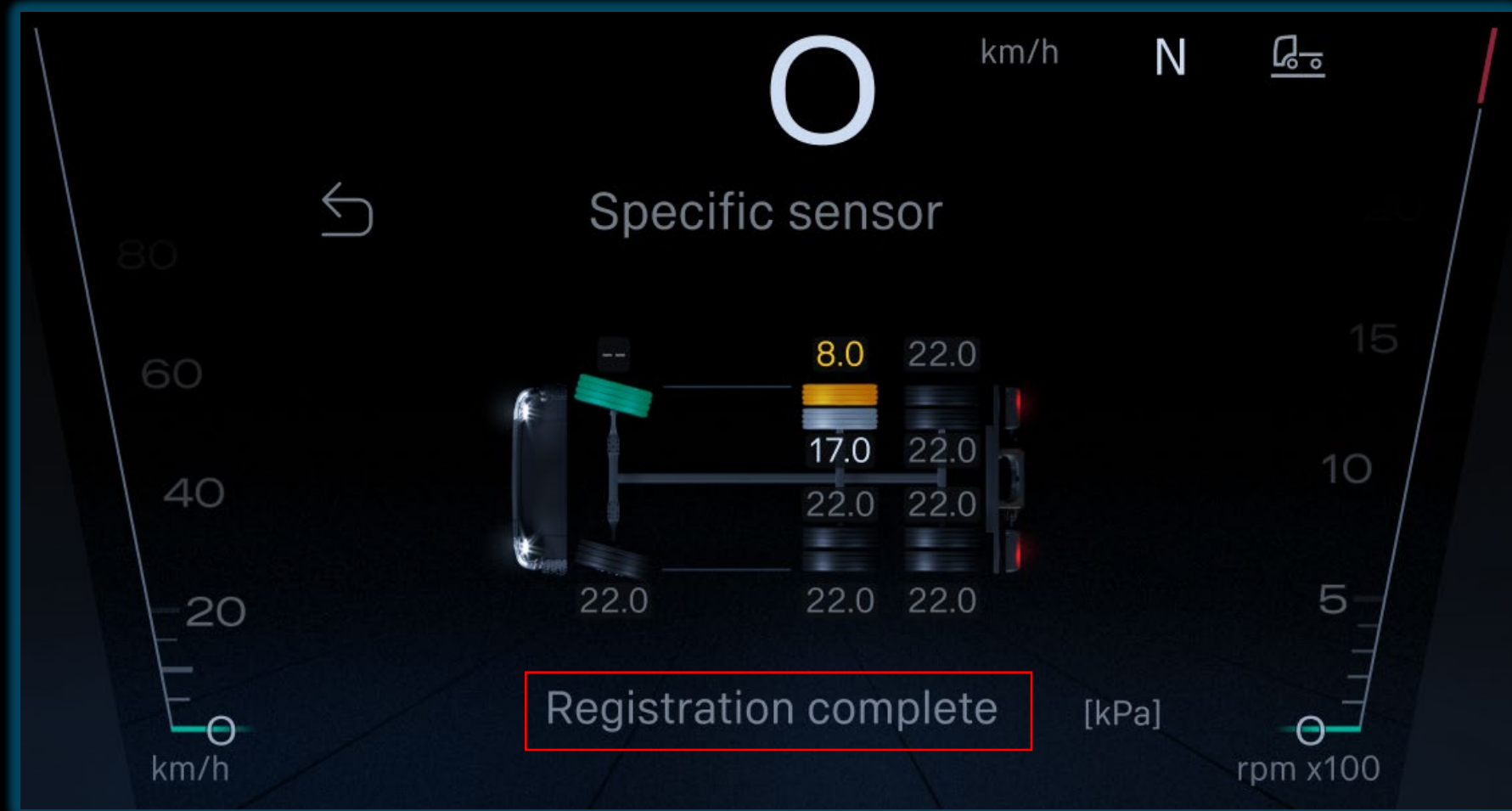



TPM PÅ TILHENGERE

SCANIA

TILHENGER TPM





TILHENGER TPM

- I tillegg til faktiske dekktrykkverdier, støttes også varsel om lavt dekktrykk for tilhengerne.
- Referansetrykkverdiene som er angitt i tilhengerens TPM-systemparametere



Low tyre pressure on trailer





TILHENGER TPM

- Dekktrykkverdiene fra tilhengeren kan ikke overvåkes av chassisets TPM2 ECU – i stedet overføres det fra tilhengerens TPMS via EBS
- ISO11992-2-protokollmelding EBS23

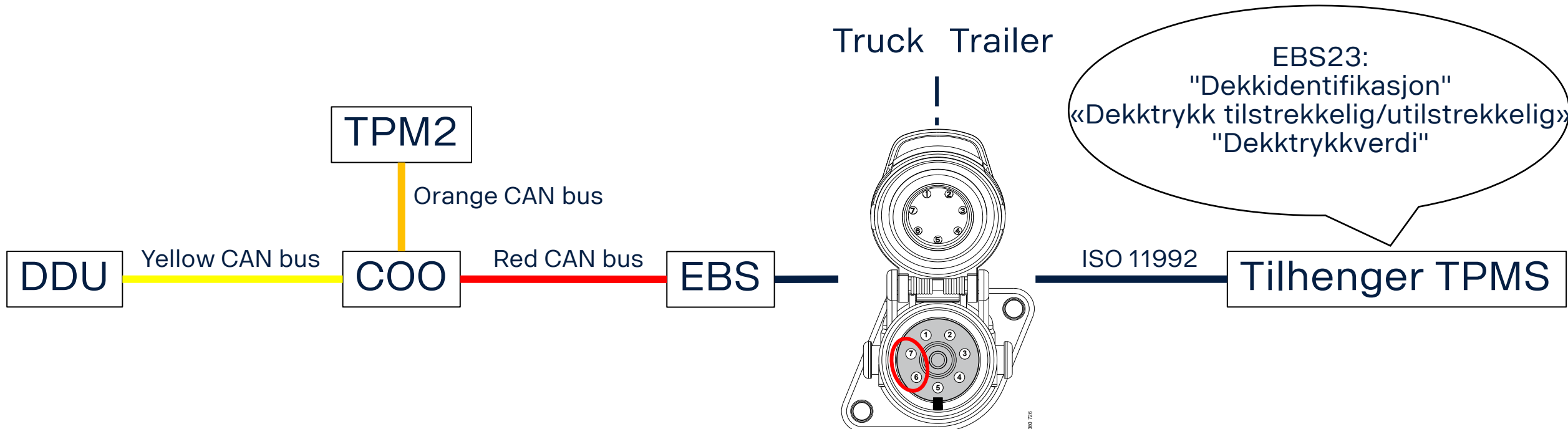



FRODE ANDREASSEN & PÅL RASTAD

SWS FOR PÅBYGGERE

SCANIA



SWS - Scania Workshop Suite



Tablet or computer

WCU, communication unit installed in the workshop



Internet, Wi-Fi



Hvordan fungerer SWS

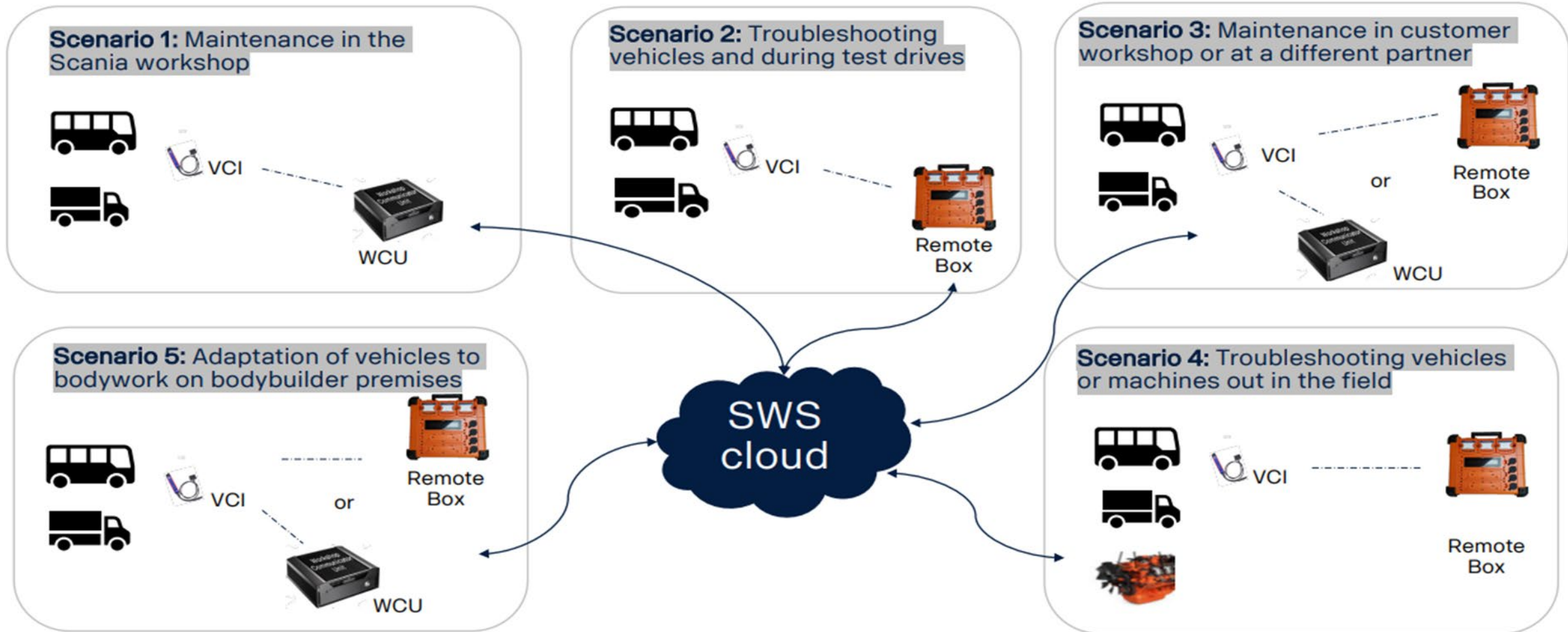



Alternativ 1

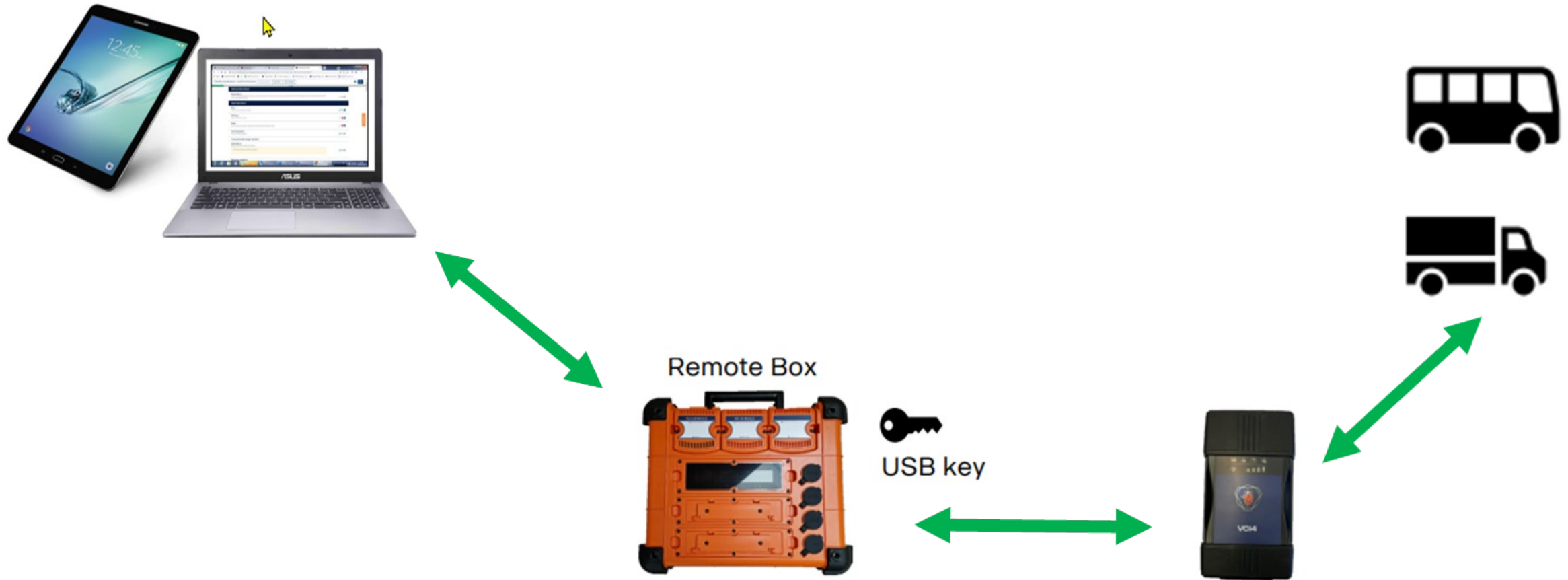



Alternativ 2

Her må lokalt nettverk settes opp med tilstrekkelige access punkt i produksjonshall

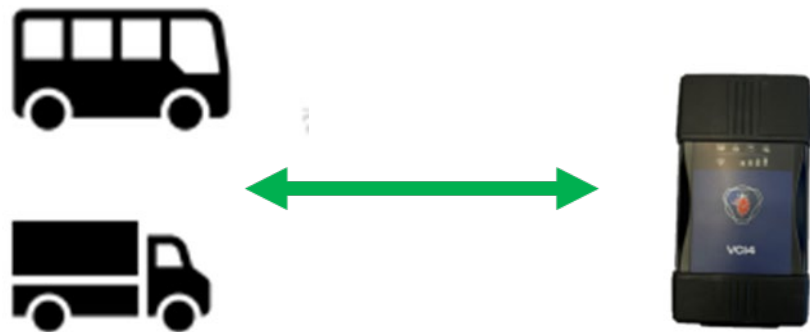

WCU, communication unit installed in the workshop

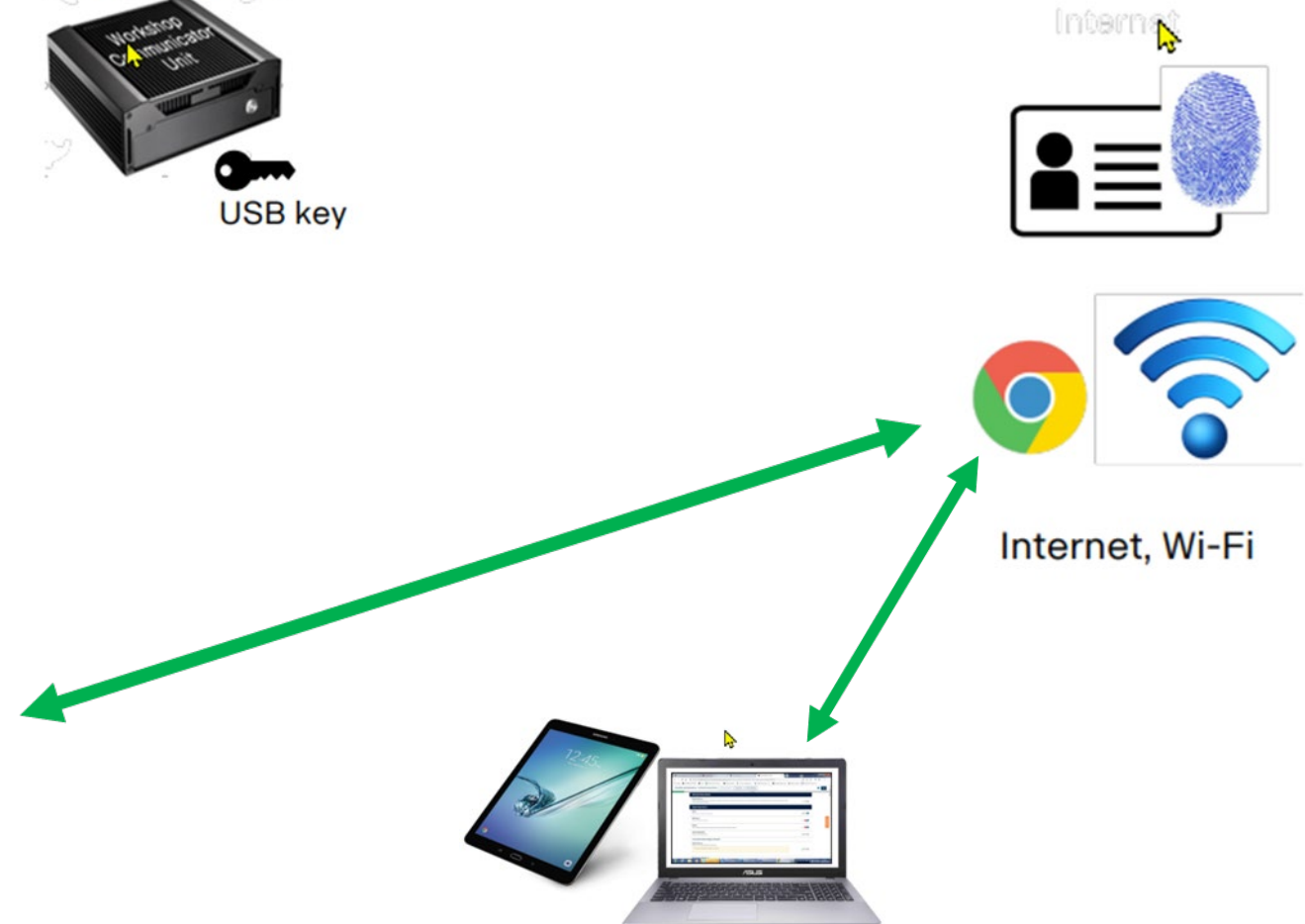



Det er behov for denne utrustningen for å kunne utføre:

- Installere BICT filer for styring av påbygg funksjoner
- Endre parametre i bilens styrings system (RPM, PTO, Nm begrensning etc.)
- Styring/oppsett av BMS sytem
- Aktivering av kontroll lamper bryter funksjoner
- Alt som tidligere ble utført i SDP3 og BICT + mye mer.....



Kjøp og abonnement kostnader

- **WCU (Workshop Communicator Unit)**

- Kjøp: kr 41.400,-
- Leasing pr år: 6 768

Innkjøp utstyr år 1: Ca. 78 190

- **USB til WCU**

- Kjøp: kr 8510,-
- Leasing pr år: kr 11 520

Årsabonnement pr. År: Ca. 29 830

- **VCI4 (Vehicle Interface 4)**

- Kjøp: kr 27.300,-
- Ingen leasing

- **SWS (Scania Workshop Suite) Bodybuilder +**
Leasing pr år: 11.500 (Tilgang til skyen)



Kontakt person ved bestilling av SWS

- jan.carlos.araya@scania.com
- Warranty Manager - Service Literature Administrator Norsk Scania AS
- Mob. +47 992 48889



SWS BRUKERE

Alle SWS-brukere må ha en XDS-konto

Dette gjelder også for brukere med bare frakoblet BICT-tilgang (SWS Bodybuilder-produkt)

Administrasjon av påbyggere 'XDS-kontoer håndteres av Norsk Scania

Logg på SWS med Azure ID = XDS ID @ scaniaweb.com

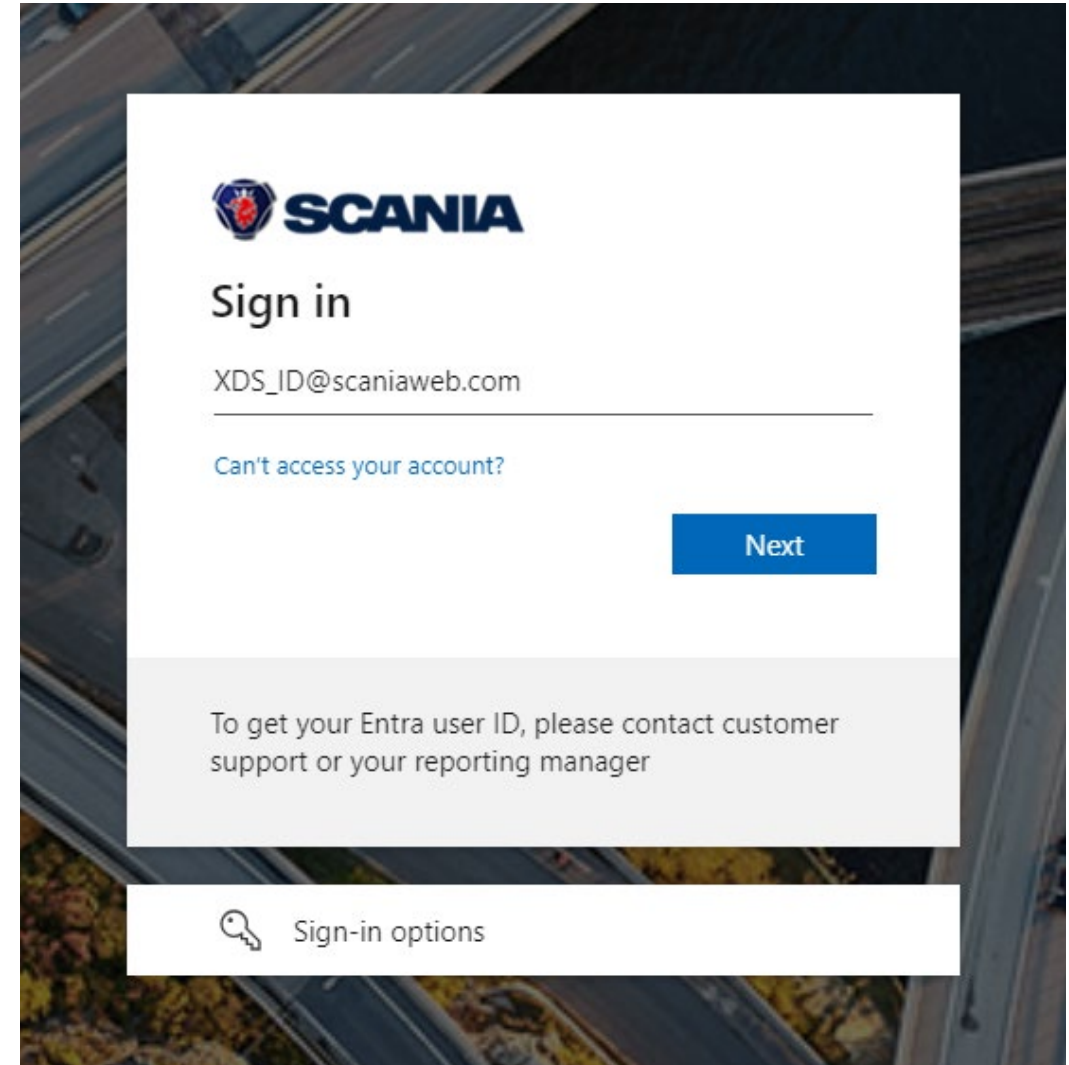



BICT PROGRAMMIERING I SWS

SCANIA

BICT PROGRAMMERING I SWS



Oppretting av en BICT-logikk direkte i SWS støttes ennå ikke

I stedet kan logikken opprettes i SDP3 "frittstående" versjon av BICT, og eksporteres i et filformat som gjenkjennes av SWS

På grunn av gjeldende begrensninger i BICT for SWS, vil det eksporterte prosjektet ikke inkludere prosjektbeskrivelse, navn på logiske diagrammer, logiske diagrambeskrivelser, signalaliaser og tekstbokser, da disse funksjonene ennå ikke støttes.



PROGRAMMERE BICT LOGIKK MED SWS

- Hvis kjøretøyet tidligere ikke har blitt programmert med BICT, må kjøretøyet ha en SOPS-ombygging for å aktivere BICT-programmering.
- En SOPS-ombygging er også nødvendig for å tillate tillegg av BCI-utvidelsesenheter.
- SOPS ombygninger må utføres av Scania verksted.

PROGRAMMERE BICT LOGIKK MED SWS



- I SDP3 oppretter du BICT-prosjektet du vil programmere til kjøretøyet.
- Når du er ferdig, klikker du på Verktøy og eksporterer som BICT-fil for SWS.
- Gi filen et navn og lagre BICT-filen på ønsket sted på PCen

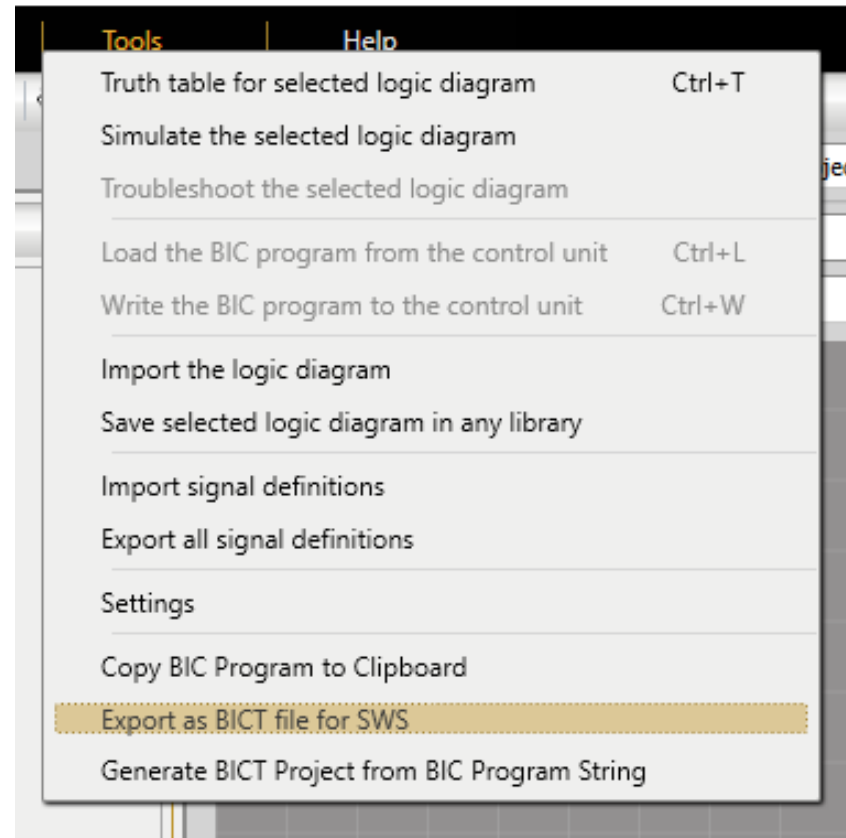



PROGRAMMERE BICT LOGIKK MED SWS

I SWS går du til **Product adaptation > Adjustment** (Produkttilpasning > Justering)
Klikk på det nederste ikonet (som viser tre prikker) i menyen til venstre, og velg deretter BICT-ikonet.

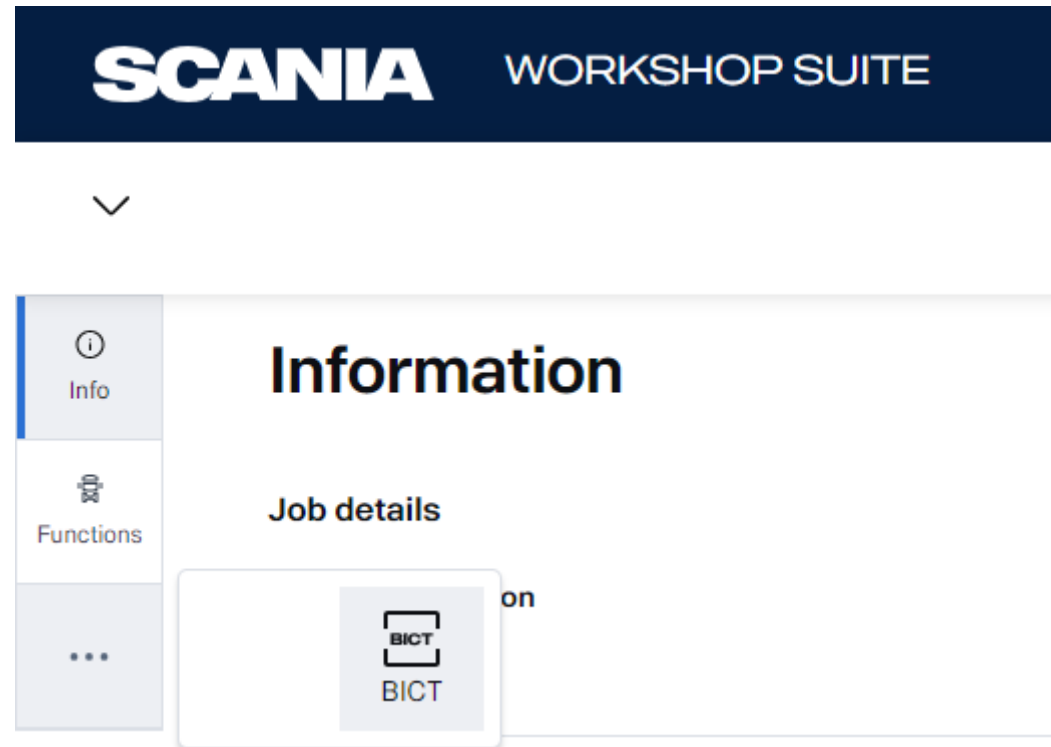



PROGRAMMERE BICT LOGIKK MED SWS

Etter en nedlasting skal BICT-programmeringsgrensesnittet vises.

I dette grensesnittet importerer du filen som ble eksportert i trinn 2 ved å klikke på Velg prosjektfil og fortsette å programere (skrive) til kjøretøyet.

The screenshot shows the Scania Workshop Suite interface. At the top, there is a dark blue header with the Scania logo and the text "WORKSHOP SUITE". Below the header, the main content area is titled "Write a BIC program to the vehicle". A sub-header reads: "The logic in the selected BIC project is written as a BIC program to the vehicle. Select a project file and click 'Write to vehicle' to proceed." Below this, there is a "File address" section with a text input field containing "SDP3_BICT_file_for_SWS.bsws" and a "Select project file" button. A warning message is displayed in a yellow box: "Programming the vehicle. By writing the program to the vehicle, you are responsible for how it affects the vehicle." At the bottom right of the interface, there is a blue button labeled "Write to vehicle".



PROGRAMMERE BICT LOGIKK MED SWS

Hvis BICT-logikk inneholder programmerbare CAN-trykknapper, er det nødvendig å fortsette med SMCT (Switch Module Configuration Tool)

NB! Hvis klikk på «Fortsett» ikke omdirigerer til SMCT, kan du i stedet nå det ved å klikke på SMCT-ikonet.

The screenshot displays the Scania Workshop Suite interface. At the top, the header reads "SCANIA WORKSHOP SUITE". The main window title is "Write a BIC program to the vehicle". Below this, a message states: "The logic in the selected BIC project is written as a BIC program to the vehicle. Select a project file and click 'Write to vehicle' to proceed." A "File address" field contains "SDP3_BICT_file_for_SWS.bsws" and a "Select project file" button is visible. A warning icon and text "Programming the vehicle" are present. A modal dialog box titled "Update SMCT" is open, containing the text: "The switches have been changed in BICT, please click 'Continue' button to update all the changes in SMCT." Below this, a step indicator shows "1 Add the switches in SMCT" with the subtext: "Programmable switches should be added in switch module configuration tool." The dialog has "Cancel" and "Continue" buttons. In the bottom right corner of the main window, a "Write to vehicle" button is visible.



KJETIL HANSEN & ROBERT STEEN

CYBERSIKKERHET

SCANIA



Innledning bakgrunn

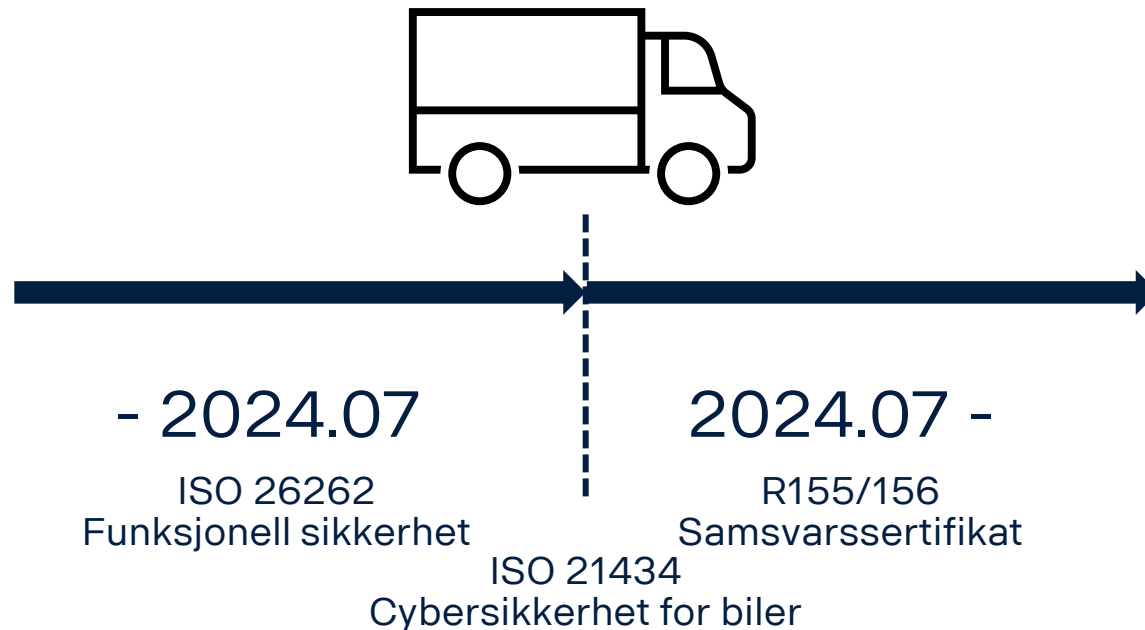

- Håndheves fra juli 2024 og fremover
- Regulert for produsenter gjennom sikkerhetsstandard for kjøretøy ISO/SAE 21434
- R155-sertifisering obligatorisk for alle nye kjøretøytyper fra juli 2022, og for alle nye kjøretøy med førstegangsregistrering fra juli 2024
- R156-sertifisering obligatorisk for alle nye kjøretøytyper fra juli 2024 der programvareoppdateringene påvirker kjøretøysertifiseringene, og for alle programvareoppdateringer på alle komplette kjøretøy fra 2029

NB: Cybersikkerhet er et myndighetskrav som gjelder for alle chassis- / påbyggsleverandører, og ikke et krav fra Scania.



TBB nyhetsbrev

SCANIA | TRUCK BODYBUILDER

Search

HOME REQUIREMENTS INSTRUCTIONS DRAWINGS AND 3D TOOLS AND SERVICES FACTORY-FITTED OPTIONS TRAINING NEWS LOCAL INFORMATION HELP

NEWS

2023.09

CYBER SECURITY AND VEHICLE SOFTWARE UPDATE REQUIREMENTS

In the European Union, new regulations on cybersecurity (UN ECE R155) and vehicle software updates (UN ECE R156) have mandatory compliance dates as follows:

- Cybersecurity (UN ECE R155):
 - Mandatory for all new vehicle types from July 2022.
 - Mandatory for all vehicles with first registration from July 2024.
- Vehicle Software Update (UN ECE R156):
 - Mandatory for all new vehicle types from July 2024.
 - Conformity to vehicle software update standards (UN ECE R156) is already mandatory for all new vehicle types from July 2022 also mandatory for all vehicles with first registration from July 2024.

These two regulations establish new requirements for automotive cybersecurity and software updates. Manufacturers or body manufacturers must have certified a CSMS (Cyber Security Management System) and a SUMS (Software Update Management System) as the basis for type approval. They must be able to demonstrate this certification to the approval authority or an institute accredited by the approval authority.

It's important to note that compliance with the basic requirements outlined in this guideline may be affected by the use of control units, radio remote controls, app applications, or updates to the existing body-specific software, among other factors.

Procedure

Within the framework of EC multi-stage type approval, each bodybuilder is responsible for obtaining approval and ensuring conformity for the production of all systems, components, or separate technical units they manufacture or add at an earlier stage in the manufacturing process. They must conduct an assessment to determine whether the body or its components are subject to the regulations.

If the body or its components fall under the scope of these regulations, it becomes the responsibility of the bodybuilder to secure the corresponding system approvals. Furthermore, during the implementation of the structure, it is imperative to identify security risks, including the potential for cyber-attacks, through a comprehensive risk assessment. These security risks should consider potential impacts on the basic vehicle and its safe operation, and appropriate measures must be taken to mitigate these risks.

For any further questions or inquiries, bodybuilders can reach out to their local Scania distributor for assistance and guidance.

Newsletter

- Sep 2023
- July 2023
- June 2023
- May 2023
- April 2023
- Jan 2023
- Dec 2022
- Nov 2022
- Oct 2022
- Sep 2022



SCANIA

INFORMATION REGARDING TYPE APPROVAL FOR CYBER SECURITY AND SOFTWARE UPDATES



UNECE REGULATION NO 155 AND 156

Together with this BBC Newsletter there is an attachment presented by Scania Type approval team with information regarding type approval for Cyber Security and Software updates. Please see attached presentation.

In any case where the changes by bodybuilder are cyber security relevant the bodybuilder needs to have their own certified CSMS. The bodybuilder needs to discuss with their technical service or type approval authority to get a common interpretation.



Konsept for cybersikkerhet

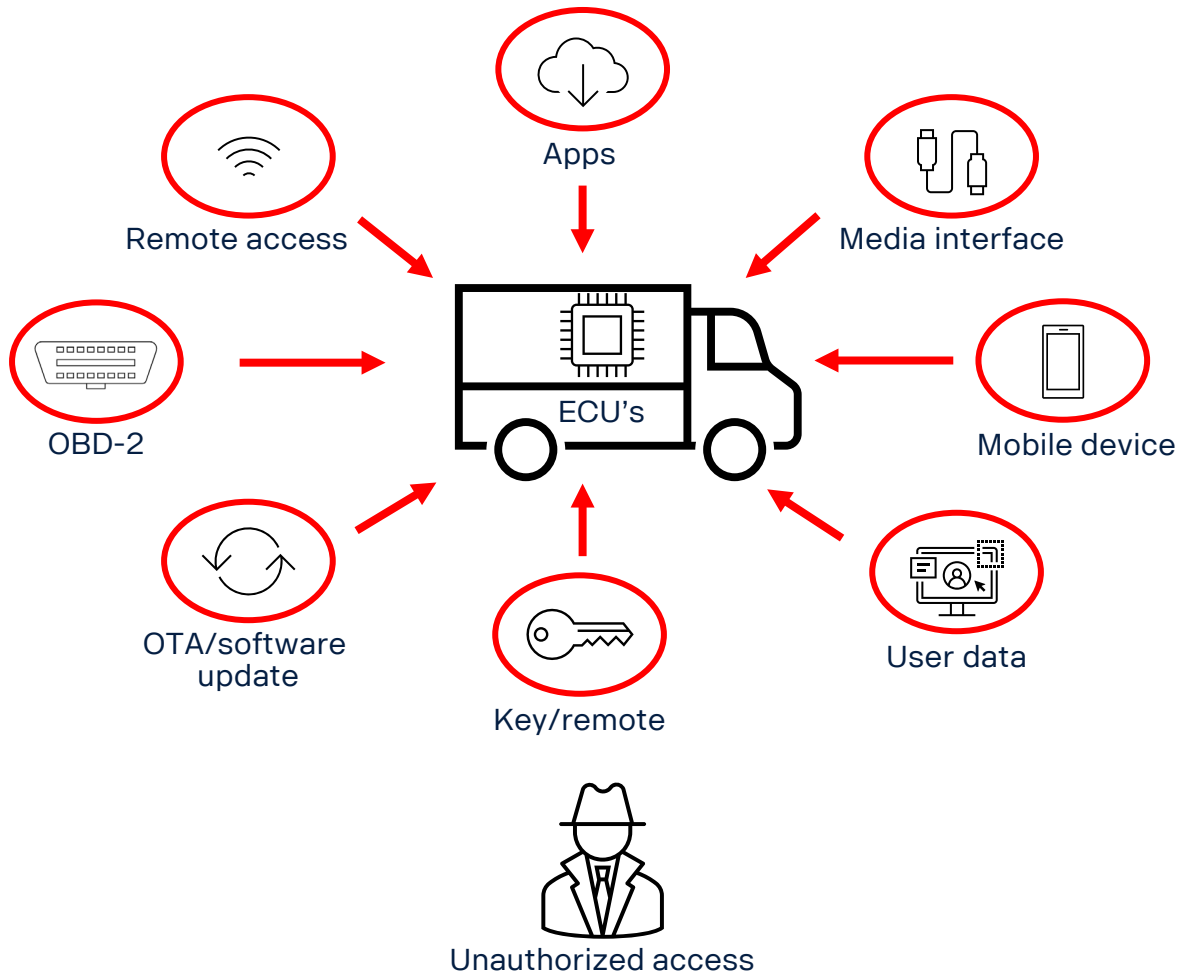

- Redusere truslene gjennom utformingen av tilganger, og minimere mulige måter å bruke disse tilgangene mot trafikantene (sjåførere / passasjerer, fotgjengere og kjøretøyets eiere)



Cybersikkerhet for påbyggere

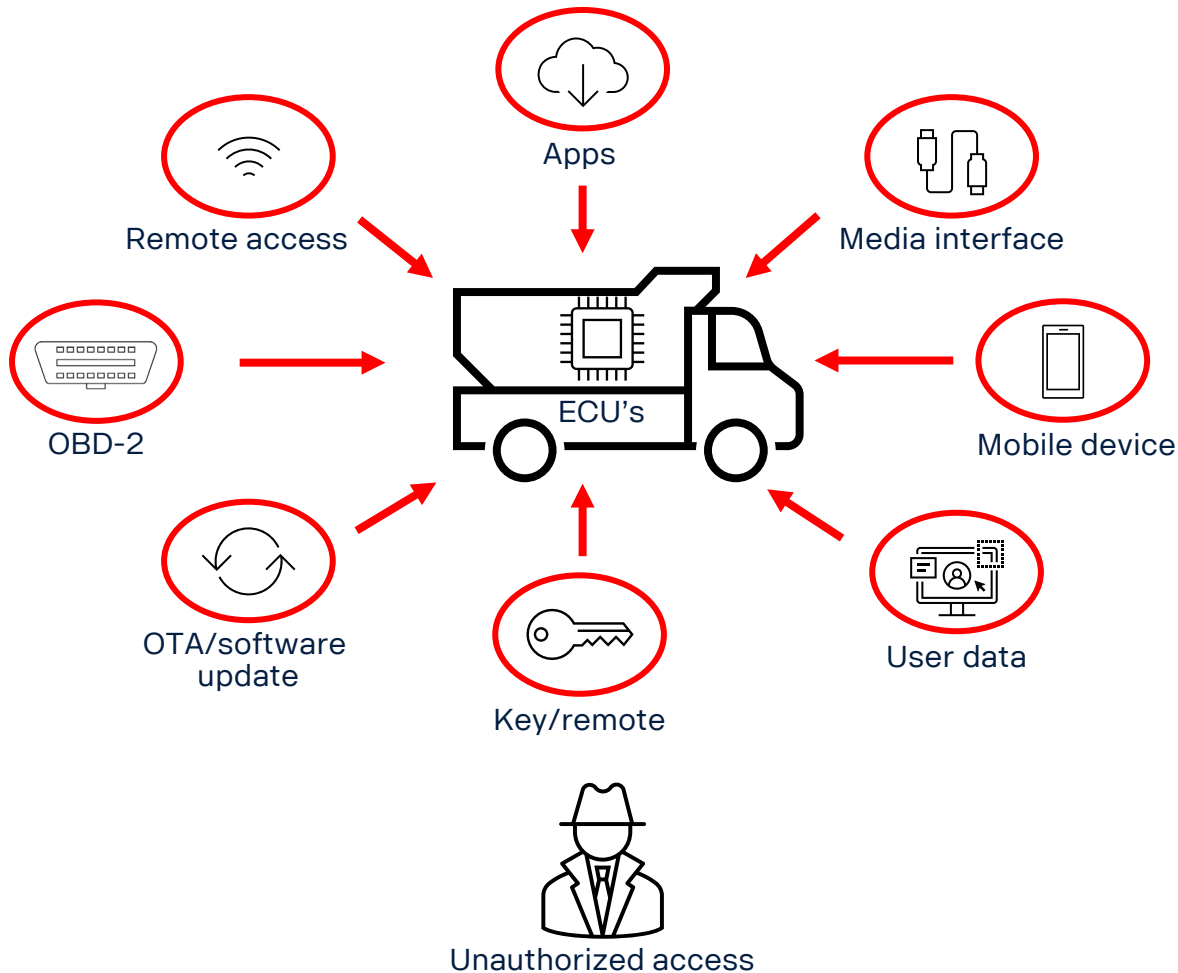

- Påbyggere har tilgang til Scania sine kjøretøyfunksjoner
- Bodywork Communication Interface (BCI ECU) gir tilgang til disse funksjonene via IO-er eller CAN-buss
- Påbyggeprodusenter må gjøre det samme som chassisprodusenter for å vurdere sin egen gate-ways design og redusere svakhetene mot uautorisert tilgang



Cybersikkerhet for påbyggere

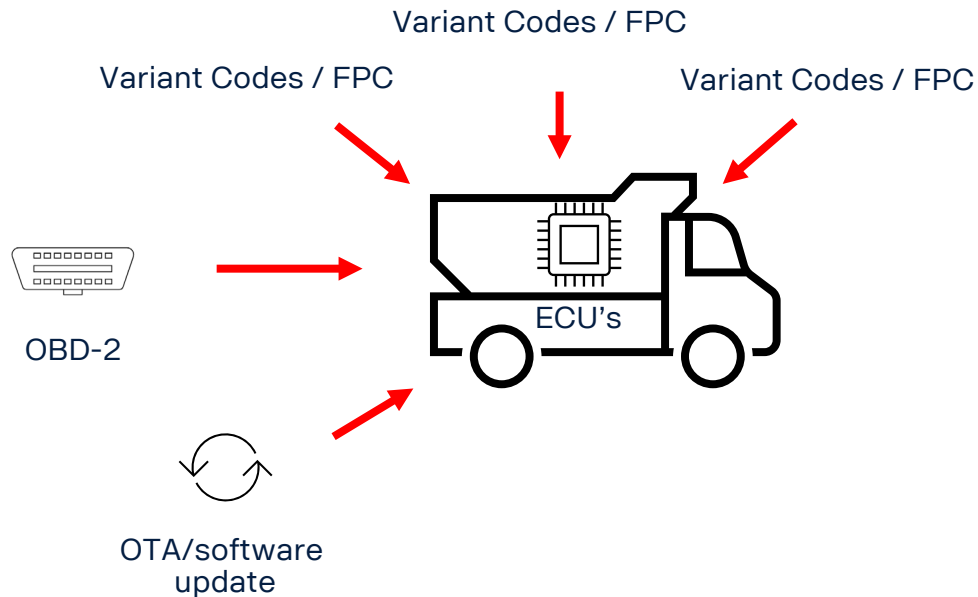

- Scania kjøretøyfunksjoner bestilt gjennom variantkoder
 - I dag åpner FPC5837A tilgang til kjøretøyfunksjoner
 - R156-kompatibel: en bestemt funksjon vil være tilgjengelig hvis den er spesifikt bestilt
- Gatewayer til diagnose og programvareoppdateringer
 - Flytt til maskinvare autorisert gjennom nettbasert autentisering, f.eks. erstattet av maskinnøkkel
 - Diagnoseverktøy som er tilgjengelig som et online verktøy



Cybersikkerhet for påbyggere

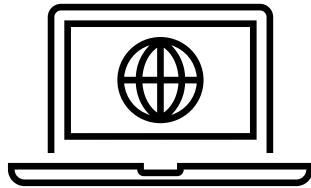

Åpen



Brukertilgang

- Scania Truck påbyggernettssted
 - Tilgang til informasjon
 - Redusert risiko ved innlogging
 - Avhengig av brukertilgang
 - Tilgang til data basert på nivåer
 - CAN spesifikasjon
 - Maskinvarebeskrivelse for CAN-buss



Prosess for analyse av cybersikkerhet

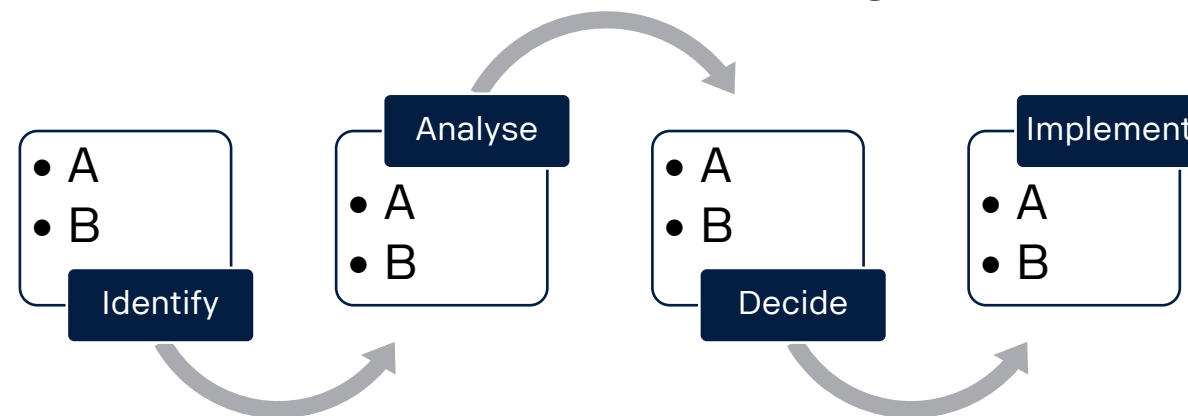

- CSMS: CyberSecurity Management System
 - Et styringssystem som gjør det mulig for selskapet å identifisere funksjoner, bestemme trusler, risiko og iverksette tiltak for å minimere risikoen på akseptabelt nivå for de styrende myndighetene
- SUMS: Software Update Management System
 - Et styringssystem som gjør det mulig for selskapet å oppdatere kjøretøyets programvare på en sikker måte (uansett oppdateringsmåte)



Eksempler?

- Identifiser hvilke funksjoner som brukes
 - Kontroll av lys
 - Motorturtall og fjæringsnivåkontroll
 - Påbygg med hydrauliske systemkontroller
- Analyser risikoen
 - Fjernkontroll for kran brukes: Hva slags radiosignal bruker vi?
 - Tilgjengelig diagnosekobling: Hva slags kommunikasjonsprotokoll bruker vi?
- Bestem en måte å redusere risikoen på
 - Maskinvare og programvare for signalkryptering
 - Sikker serviceinformasjon
 - Sikker programvare
- Implementer det hele veien
 - Tilgang til autorisert bruker-ID-informasjon
 - Lisensierte verktøy
 - Lisensbaserte oppdateringer
 - Vedlikeholdsprosess

SCANIA



INFORMATION REGARDING TYPE APPROVAL FOR CYBER SECURITY AND SOFTWARE UPDATES



If the changes are cyber security relevant or related to the Scania E/E Architecture but without any modification, the bodybuilder must explain to the technical service or the type approval authority why the changes are not cyber security relevant (e.g., connecting a third-party fleet management that can report fuel consumption and / or position). In this case, the bodybuilder may not need to have their own certified CSMS but needs to confirm this with the technical service or the type approval authority.

If changes made by the bodybuilder are cyber security relevant, (e.g., modifying the Scania E/E architecture by adding a crane that can increase the engine speed) the bodybuilder needs to have their own certified CSMS.

No SUMS is needed for the bodybuilder if systems with software update capabilities are not installed. If systems added by the bodybuilder have software update capability, the bodybuilder needs to have their own certified SUMS*. The bodybuilder needs to discuss with their technical service or







<p>Scania type approval</p>  <p>Scania R155/ R156 system approval</p>   <p>ECU 1 ... ECU N</p>	<p>Second stage type approval</p>  <p>Bodybuilder additional ECUs</p>   <p>ECU N+1 ...</p>
---------------------------------------------------------------------------------------------------------------------------------------------------------------------------------------------------------------------------------------------------------------------------------------------------------------------------------------------------------------------	--------------------------------------------------------------------------------------------------------------------------------------------------------------------------------------------------------------------------------------------------------------------------------------------------------------------------------------------------------------

Figure 2. ECUs installed from the bodybuilder must be handled during second stage type approval.



Cybersikkerhet relevans for påbyggere

For å avgjøre om komponenter i tunge kjøretøy er cybersikkerhetsrelevante, må påbyggeprodusenter vurdere flere faktorer som er relatert til sikkerheten og sikkerheten til kjøretøyets elektroniske systemer. Her er en omfattende tilnærming:

- **1. Forstå funksjonene i kjøretøyarkitekturen**

Kartlegg kjøretøyets funksjoner som karosseriprodusentene bruker/samhandler med, og identifiser den valgte metoden for å integrere med disse funksjonene. Bestem hvordan disse karosserisystemene samhandler med kjøretøysystemer (for eksempel trådløse tilkoblinger, telematikk osv.).

- **2. Identifisere kritiske systemer og komponenter**

- **Sikkerhetskritiske systemer:** Identifiser komponenter relatert til styring, bremsing, akselerasjon, motorstyring, etc. Hvis de blir kompromittert, kan disse føre til katastrofale utfall.
- **Driftskritiske systemer:** Komponenter som påvirker kjøretøyets drift, som transmisjonskontroller, drivstoffsystemer og fjæring.
- **Kommunikasjonssystemer:** Systemer som muliggjør intern (nettverk i kjøretøyet) og ekstern kommunikasjon (telematikk, tilkobling med andre kjøretøy eller infrastruktur).
- **Brukergrensesnitt og underholdningssystemer:** Selv om de ikke umiddelbart er sikkerhetsrelaterte, kan disse være inngangspunkter for angrep.

- **3. Vurder sårbarhet og angrepsmuligheter**

- **Eksterne grensesnitt:** Fastslå hvor ekstern kommunikasjon skjer, for eksempel Bluetooth, Wi-Fi, USB-porter eller telematikktilkoblinger. Disse grensesnittene er vanlige angrepssektorer.
- **Kommunikasjon mellom komponenter:** Se etter punkter der data overføres mellom komponenter, da dette er potensielle sårbarheter.
- **Programvare og Maskinvare:** Identifiser komponenter med oppdaterbar programvare/maskinvare, da disse kan være mål for skadelig programvare eller andre ondsinnede aktiviteter.



Cybersikkerhet relevans for påbyggere

- **4. Vurdere forskrifts- og industristandarder**

Undersøk forskrift og retningslinjer for cybersikkerhet som er spesifikke for tunge kjøretøy, for eksempel ISO / SAE 21434 ("Road Vehicles - Cybersecurity Engineering"). Gjennomgå andre relevante forskrifter som påbyggsutstyr skal følge, og foreta en kryssjekkanalyse med cybersikkerhetskrav.

- **5. Fastslå virkningen av cybersikkerhetstrusler**

- **Sikkerhetskonsekvens:** Vurder potensielle sikkerhetsrisikoer hvis en komponent eller funksjon er kompromittert.
- **Driftspåvirkning:** Vurder innvirkningen på kjøretøyets ytelse og pålitelighet.
- **Datasikkerhet:** Identifiser komponenter som håndterer sensitive data eller personlig informasjon.

- **6. Utvikle en cybersikkerhetsplan**

- **Risikovurdering:** Gjennomfør en risikovurdering for å identifisere høyrisikokomponenter og deres potensielle sårbarheter.
- **Trusselmodellering:** Modeller potensielle trusler og hvordan de kan utnytte sårbarheter.
- **Begrensingsstrategier:** Utvikle strategier for å redusere identifiserte risikoer, for eksempel kryptering, autentisering, inntrengingsdeteksjon og sikre oppstartsprosesser.

- **7. Løpende overvåking og respons**

Implementere mekanismer for kontinuerlig overvåking av komponenter for unormal oppførsel eller sikkerhetsbrudd.

Etablere hendelsesresponsprotokoller i tilfelle cybersikkerhetshendelser.

Ved å følge disse trinnene kan påbyggsprodusenter identifisere hvilke komponenter som er cybersikkerhetsrelevante og utvikle passende strategier for å sikre dem, noe som til slutt sikrer både sikkerheten og påliteligheten til tunge kjøretøy.



Cybersikkerhet relevans for påbyggere

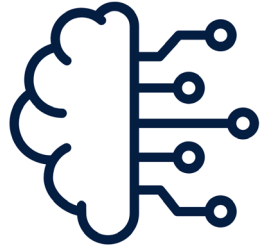

- **1. Forstå kjøretøyarkitekturfunksjoner**

Kartlegg kjøretøyets funksjoner som påbyggerprodusentene bruker/samhandler med, og identifiser den valgte metoden for å integrere med disse funksjonene.

Fastslå hvordan disse påbyggersystemene samhandler med kjøretøysystemer (for eksempel trådløse tilkoblinger, telematikk osv.).



Cybersikkerhet relevans for påbyggere

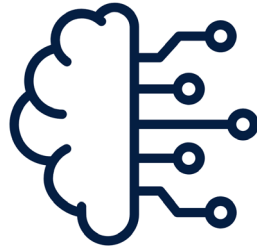

• 2. Identifisere kritiske systemer og komponenter

- **Sikkerhetskritiske systemer:** Identifiser komponenter relatert til styring, bremsing, akselerasjon, motorstyring, etc. Hvis de blir kompromittert, kan disse føre til katastrofale utfall.
- **Driftskritiske systemer:** Komponenter som påvirker kjøretøys drift, som transmisjonskontroller, drivstoffsystemer og fjæring.
- **Kommunikasjonssystemer:** Systemer som muliggjør intern (nettverk i kjøretøyet) og ekstern kommunikasjon (telematikk, tilkobling med andre kjøretøy eller infrastruktur).
- **Bruergrensesnitt og underholdningssystemer:** Selv om de ikke umiddelbart er sikkerhetsrelaterte, kan disse være inngangspunkter for angrep.



Cybersikkerhet relevans for påbyggere

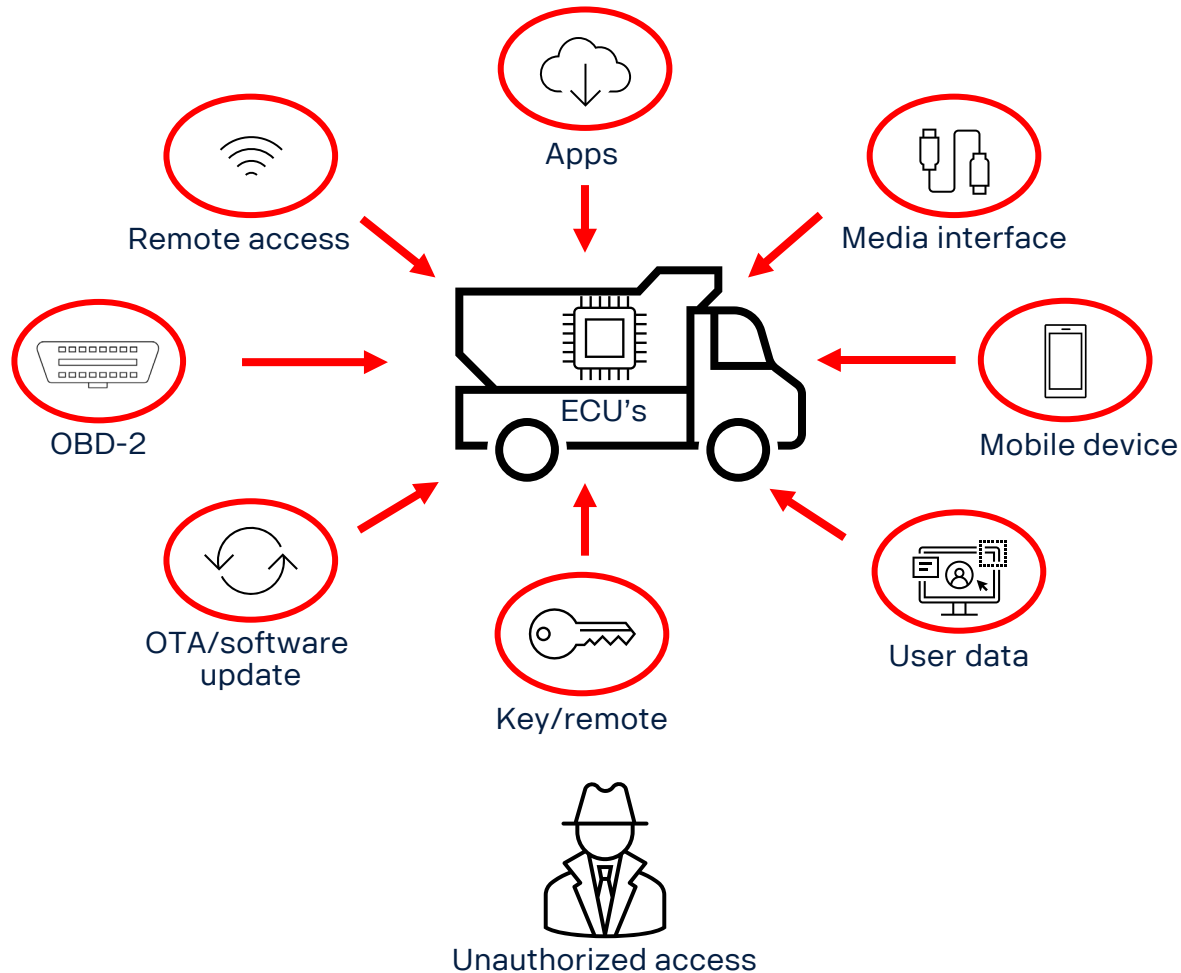

• 3. Vurder sårbarhet og angrepsveier

- **Eksterne grensesnitt:** Fastslå hvor ekstern kommunikasjon skjer, for eksempel Bluetooth, Wi-Fi, USB-porter eller telematikktilkoblinger. Disse grensesnittene er vanlige angrepssektorer.
- **Kommunikasjon mellom komponenter:** Se etter punkter der data overføres mellom komponenter, da dette er potensielle sårbarheter.
- **Programvare og fastvare:** Identifiser komponenter med oppdaterbar programvare/fastvare, da disse kan være mål for skadelig programvare eller andre ondsinnede aktiviteter.



Cybersikkerhet relevans for påbyggere

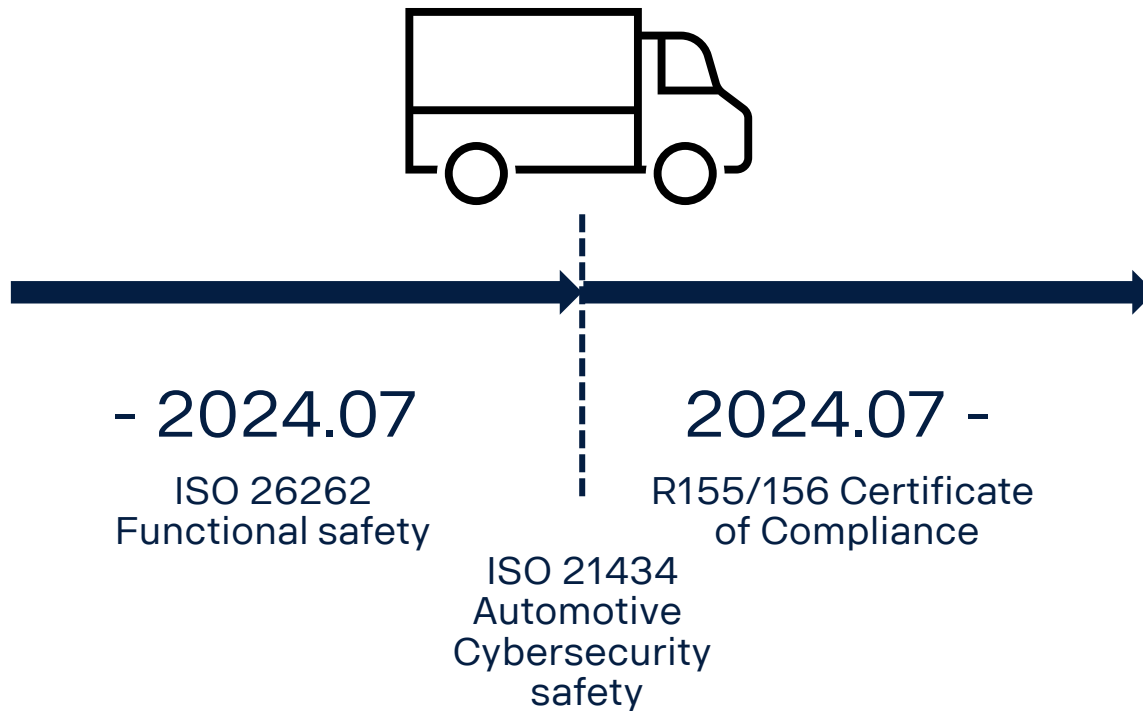

- 4. Vurdere forskrifts- og industristandarder

Undersøk forskrift og retningslinjer for cybersikkerhet som er spesifikke for tunge kjøretøy, for eksempel ISO / SAE 21434 ("Road Vehicles - Cybersecurity Engineering").

Gjennomgå andre relevante forskrifter som påbyggerutstyr skal følge, og foreta en kryssjekkanalyse med cybersikkerhetskrav. Ingen krav setter det andre til siden, men begge må oppfylles.



Cybersikkerhet relevans for påbyggere

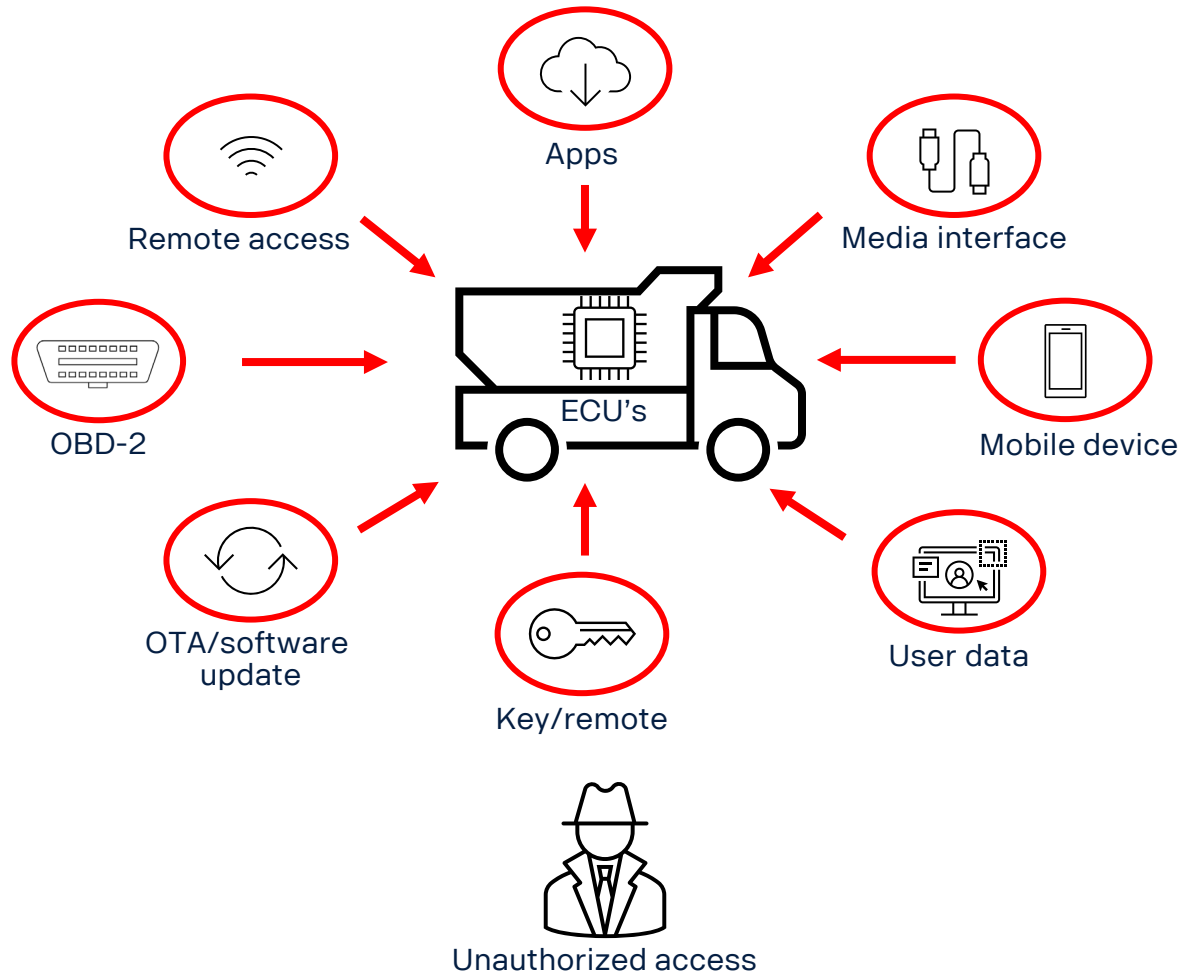

• 5. Fastslå virkningen av cybersikkerhetstrusler

- **Sikkerhetskonsjens:** Vurder potensielle sikkerhetsrisikoer hvis en komponent eller funksjon er kompromittert.
- **Driftspåvirkning:** Vurder innvirkningen på kjøretøyets ytelse og pålitelighet.
- **Datasikkerhet:** Identifiser komponenter som håndterer sensitive data eller personlig informasjon.

• 6. Utvikle en cybersikkerhetsplan

- **Risikovurdering:** Gjennomfør en risikovurdering for å identifisere høyrisikokomponenter, og deres potensielle sårbarheter.
- **Trusselmodellering:** Modeller potensielle trusler og hvordan de kan utnytte sårbarheter.
- **Begrensingsstrategier:** Utvikle strategier for å redusere identifiserte risikoer, for eksempel kryptering, autentisering, inntrengingsdeteksjon og sikre oppstartsprosesser.



Cybersikkerhet relevans for påbyggere



- **7. Løpende overvåking og respons**

Implementere mekanismer for kontinuerlig overvåking av komponenter for unormal oppførsel eller sikkerhetsbrudd.

Etablere hendelsesresponsprotokoller i tilfelle cybersikkerhetshendelser.

Ved å følge disse trinnene kan påbyggsprodusenter identifisere hvilke komponenter som er cybersikkerhetsrelevante, og utvikle passende strategier for å sikre dem, noe som til slutt sikrer både sikkerheten og påliteligheten til tunge kjøretøy.

Kriterieeksempler på relevans for cybersikkerhet

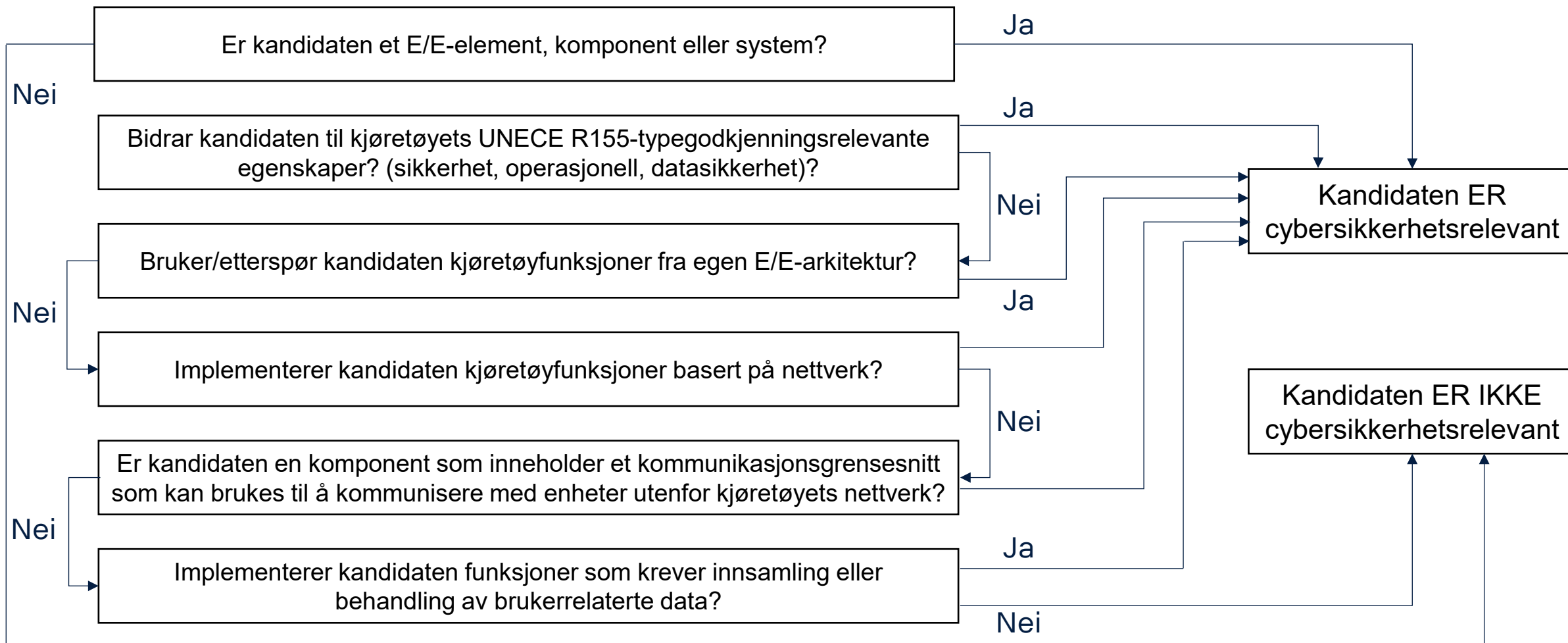



FRODE ANDREASSEN & PÅL RASTAD

ARBEID PÅ CHASSIS BEV & GASS SIKKERHETSRUTINER

SCANIA



Sikkerhetsrutine ved arbeid på BEV biler

VARNING!

Arbete med eldriftssystemet får endast utföras på Scaniaverkstad av personal kvalificerad enligt EN 50110, eller motsvarande för marknader utanför Europa.

Enheter försedda med varningsskylt får bara öppnas av kvalificerad Scaniapersonal, se bild.

Elektriskt kraftuttag är ett undantag och kan anslutas av annan kvalificerad personal.



Varningsskylt för klass B-spänning.

Spänning	DC (Likström)	AC (Växelström)
Klass A-spänning	0–60 V	0–30 V
Klass B-spänning	60 V–1 500 V	30–1 000 V

To varianter av BEV biler fra Scania

Type A = BEV 1

Type B = BEV 3

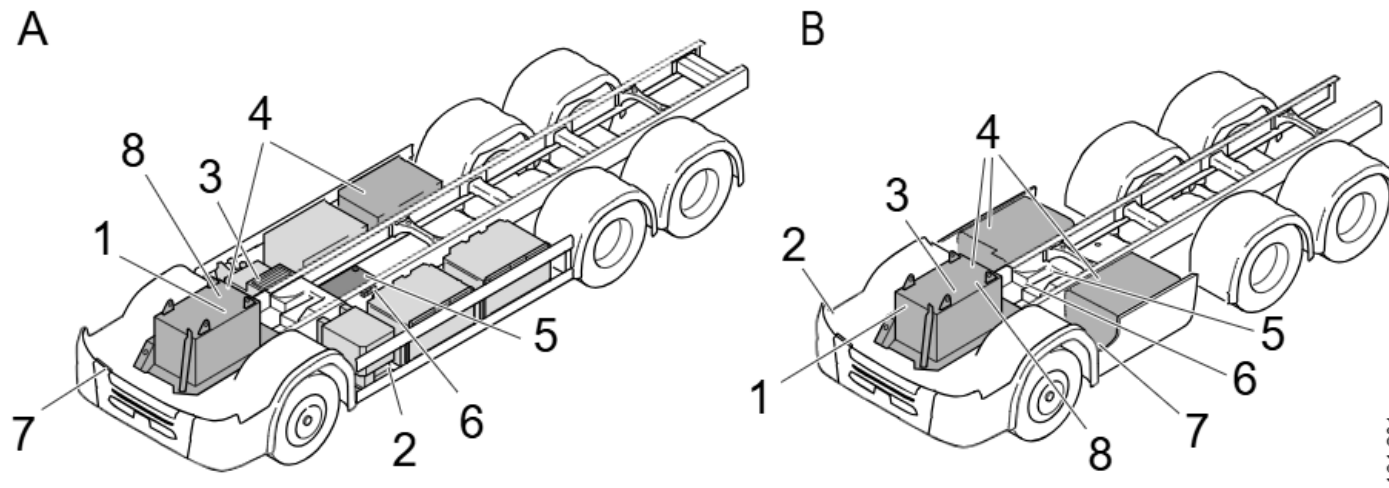

464 201

Pos	Beskrivning
1	Kraftelektronik
2	Manöverbrytare för eldriftssystem (VCB)
3	Elektrisk luftkompressor
4	Framdrivningsbatterier
5	Elmotor och växellåda
6	Ledningsnät för klass B-spänning (VCB) - orange ledningsnät
7	Ladduttag för CCS-laddning
8	Elektriskt kraftuttag

Før all type verkstedarbeid



- Sikre og merk tydelig arbeidsplassen rundt hele kjøretøyet. Uvedkommende skal gjøres oppmerksomme på at elarbeid på elkjøretøy pågår.
- Slå av det elektriske systemet med manøverbryter S229
- Manøverbryteren er plassert bak venstre forhjul (BEV 1) eller bak i grill (BEV 3)

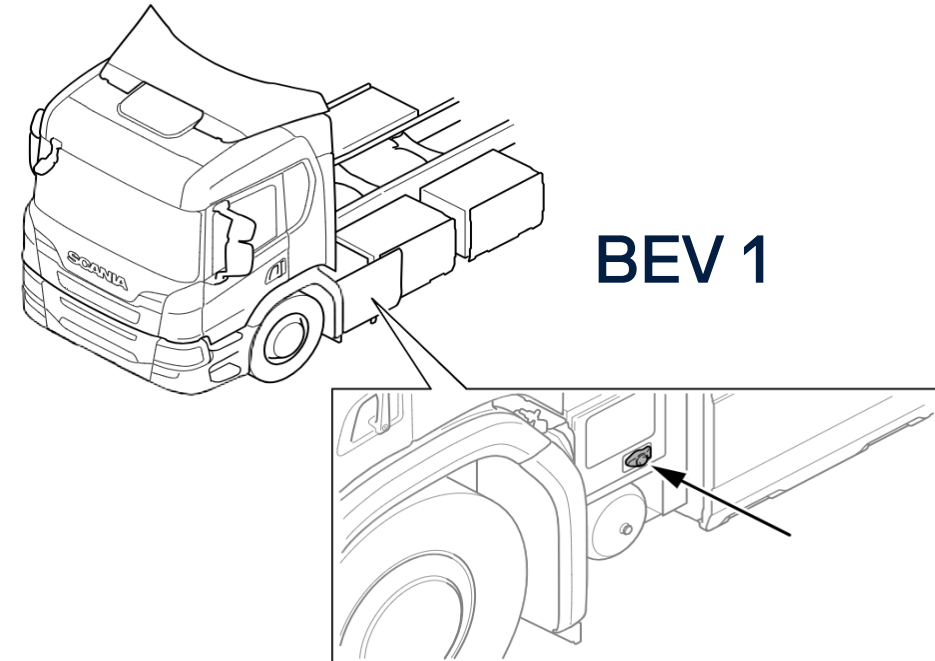
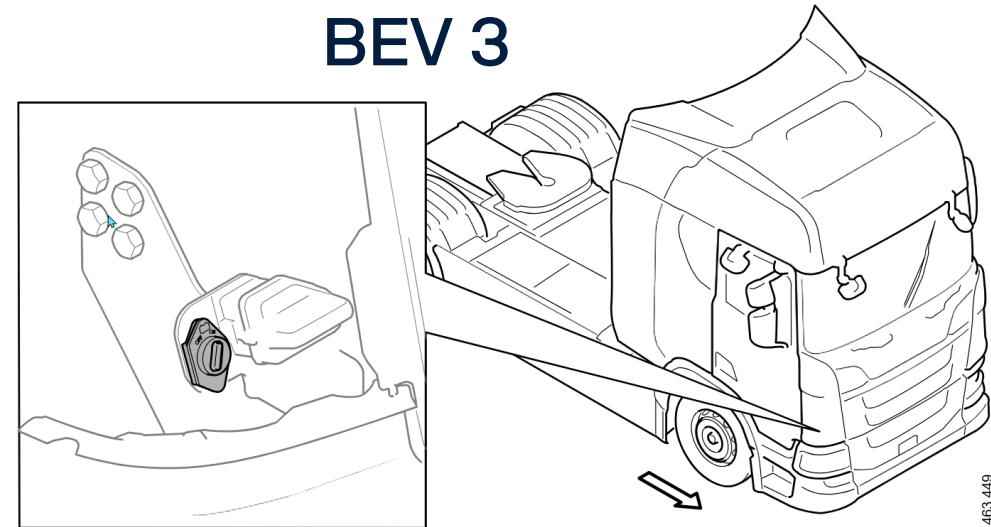

463 449

425 556



Kontroller at el drifts-systemet er slått AV

- Slå på 15 spenningen.(Tenningsnøkkel)
- Kontroller at kjøretøyet ikke kan startes.
- Kontroller at feilmeldingen Elektriske drivsystemet er slått av vises i ICL



- Lås hovedbryter med hengellås sammen med tenningsnøkkel slik at hver person som arbeider med kjøretøyet fester sin personlige hengellås.
- På denne måten kan ikke systemet slås på før alle har avsluttet arbeidet og hengellåsene er fjernet.

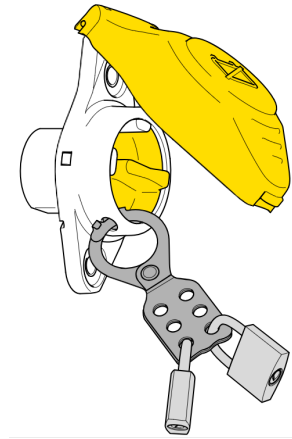

BEV 1

BEV 3

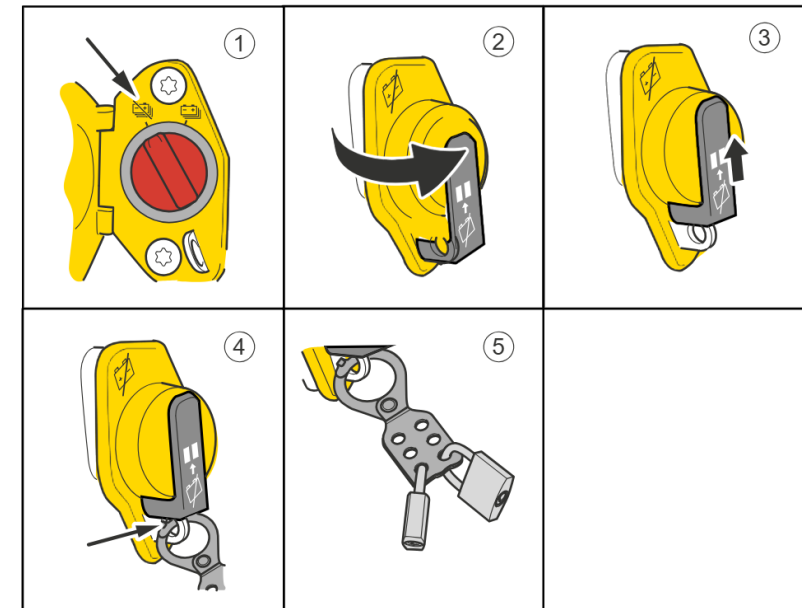



Arbeid som kan utføres ved denne type nedstengning:

- Alt av mekanisk arbeid (service, bremses, chassis, påbygggnasjoner etc..)
- Alt av arbeid på 24 Volt systemet

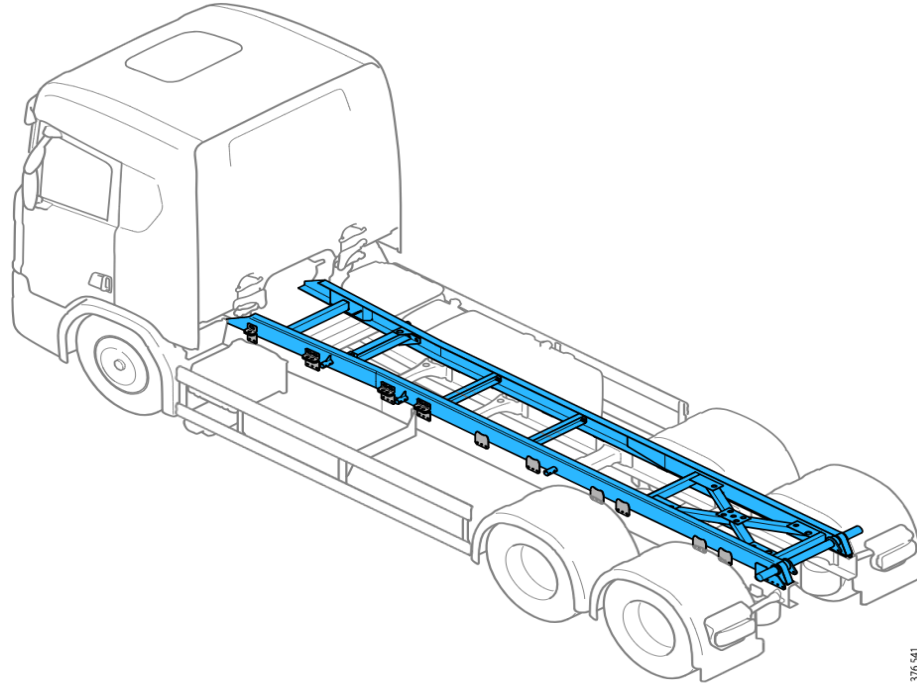



Reparasjoner/kontroll av VCB systemet

- Det vil si alt arbeid som involverer alle komponenter eller kabelforbindelser i VCB systemet.
- Krever spesifikk dokumentert kompetanse.
(Europeisk standard EN 50110-1)
- F.eks. Innkobling av el. PTO (aggregat, varmesystemer etc.
som benytter høy spenning 650V >

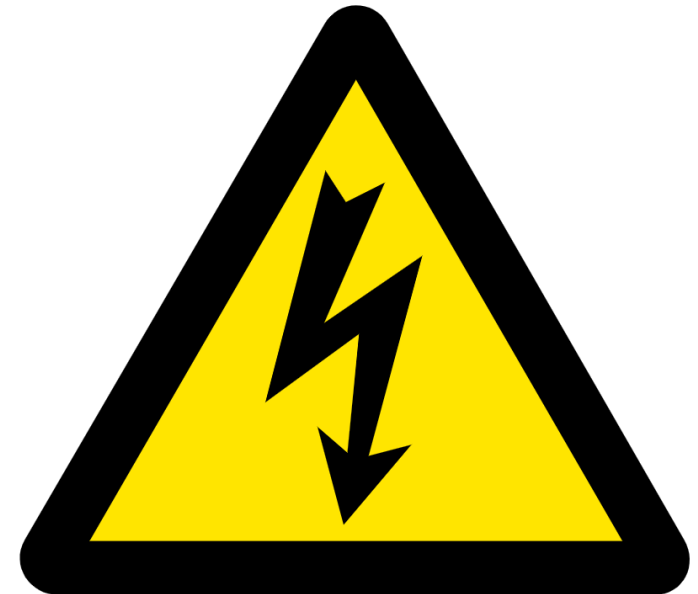

442 961



GASS BILER SIKKERHETSRUTINER



Allmenn informasjon om gass og sikkerhet

- To typer gass brukes av Scania
- CNG (CBG) er gass som lagres i romtemperatur under høyt trykk(ca 200 bar)
- LNG (LBG) er gass som kjøles ned til -162 grader og lagres flytende
- Alt arbeid som utføres på chassis må gjøres etter ECE-R110
- Gassen er meget lettantennelig og må håndteres deretter
- Plasser bilen på en slik måte at den enkelt kan trekkes ut i tilfelle brann eller andre hendelser i verkstedet.
- Løsne **aldri** rørkoblinger som er trykk satt



Levering fra fabrikk

Ikke noe flytende drivstoff hindrer boiloff

Kjøredistanse ~0,7 km pr bar over 7 bar og pr tank.



21 bar(g) 
Safety

16 bar(g) 

10-15 bar gass.
= ~2-4 kg utnyttbart drivstoff

Gass



Avkoking

Når et LNG-kjøretøy står stille over lengre tid, øker trykket i tanken når motoren er slått av. Det skyldes at temperaturen i gasstanken øker og LNG fordamper. Fordampingen skjer imidlertid ikke umiddelbart. En ny tank som er full av LNG og har et trykk på 10 bar, slipper ikke ut fordampet LNG før det har gått 5 dager.

Tanktrykk Holdetid

10 bar	5 dager
11 bar	4 dager
12 bar	3 dager
13 bar	2 dager
14 bar	1 dag

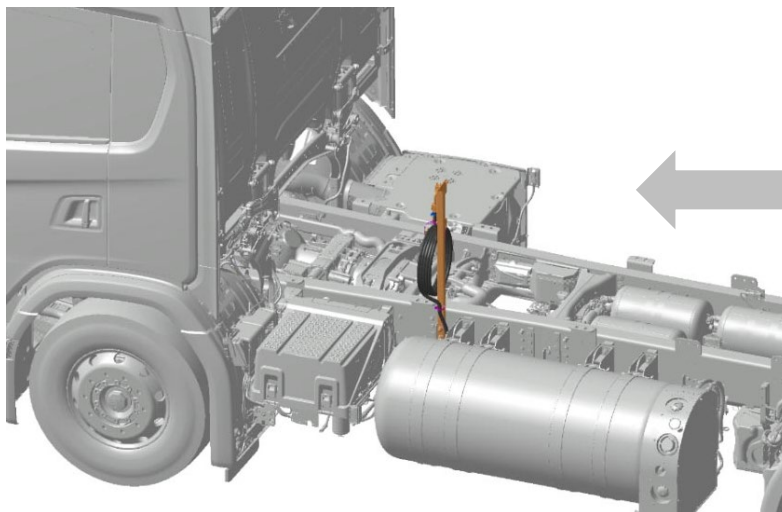

Produktoversikt – midlertidig montert brakett for avkokingslanger

Avkokingsenheten er midlertidig montert på en brakett. Montasjen må fullføres av en påbygger. Instruksjonene er tilgjengelige på Scania's nettside for påbyggere.

Merk at disse tidene er tilnærmede verdier og gjelder full tank. Holdetiden synker over tid fordi undertrykket mellom tankveggene gradvis forringes. Trykket øker dessuten raskere i en tank som ikke er helt full. Det økte trykket fører til at en sikkerhetsventil åpnes og trykket utlignes slik at tanken ikke blir ødelagt.



Når kjøretøyet tas inn på verkstedet

Skilt i og utenfor for verkstedet

4 skilt rundt bil og 1 skilt på utsiden av verkstedsport er minimumskravet

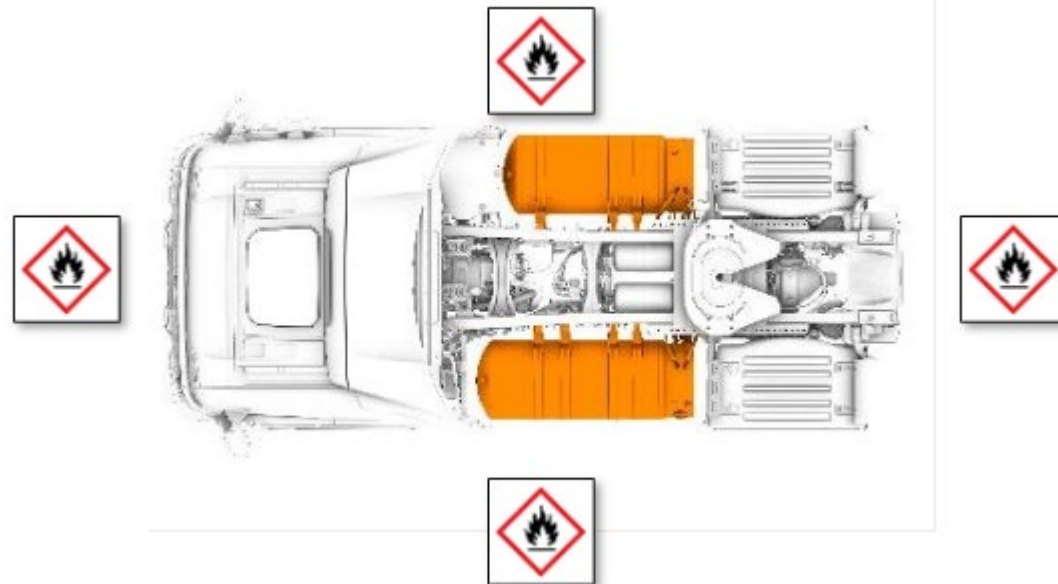



Nedstengning av gass bil på verksted

1. Stans bil utenfor verksted og utfør lekkasje måling med gassdetektor (Scania del nr: 2380848). Max tillatt lekkasje er 0,2 % LEL (100 ppm)
2. Kjør inn bil og la motor gå. Steng av hoved kran og la motor gå til den stopper av seg selv. Steng så av tenning og hovedbryter.
3. På LNG biler kobles evakuerings sats til tank og ledes utenfor.
4. Fyll ut kontroll dokument for lekkasje fri kjøretøy og heng dette opp på frontrute. Marker rundt bilen med 4 kjepler og skilt gass under trykk samt et gass under trykk skilt på utsiden verkstedport.
5. Ved lengere opphold, utfør gass deteksjon hver morgen før arbeidet begynner.



Lekkasjesøk risiko områder CNG

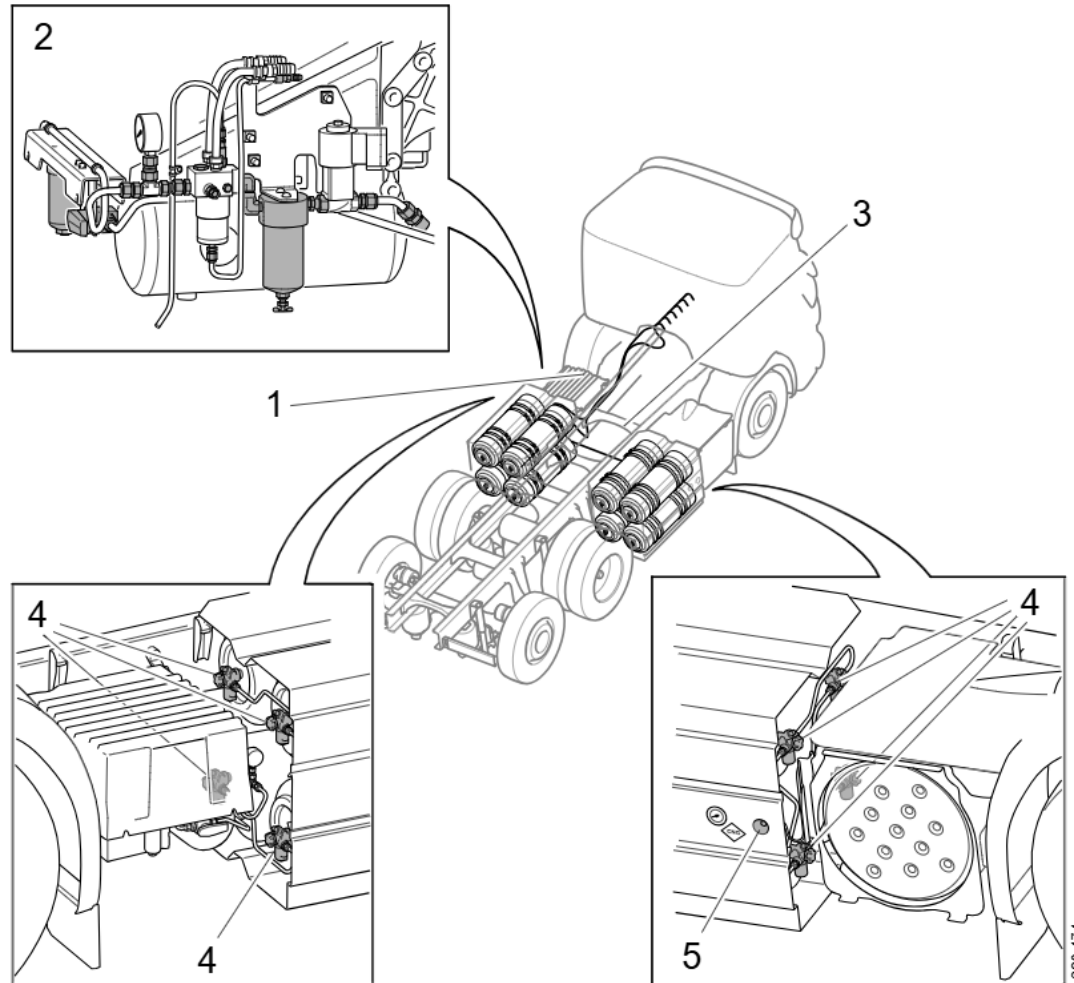

1. Rørkoblinger mellom gasspanel og motor inkludert brensel list.
2. Rørkoblinger og komponenter på gasspanelet.
3. Rørkoblinger mellom tanker og gasspanel.
4. Tankventiler og sikkerhetsventiler.
5. Tankpåfylling.



Ventilasjon av LNG tanker

1. Forsikre deg om at de manuelle ventilene er stengt.
Er to typer tanker

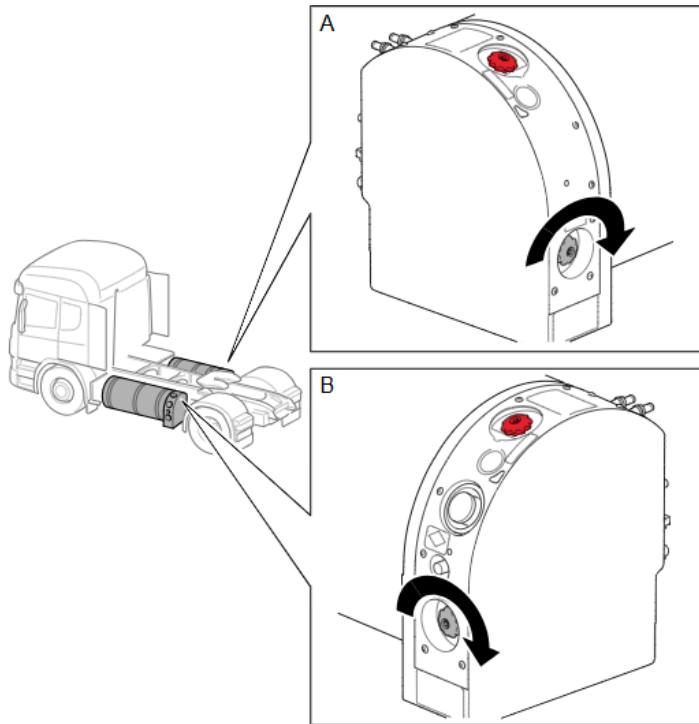

SAG tank

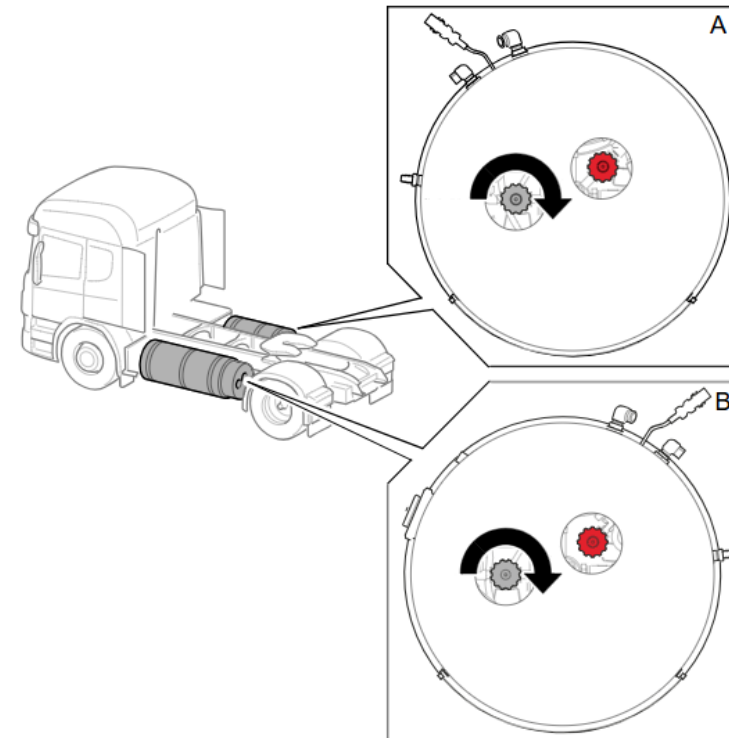

Chart tank



2. Blås rent rundt ventilasjonsventilen

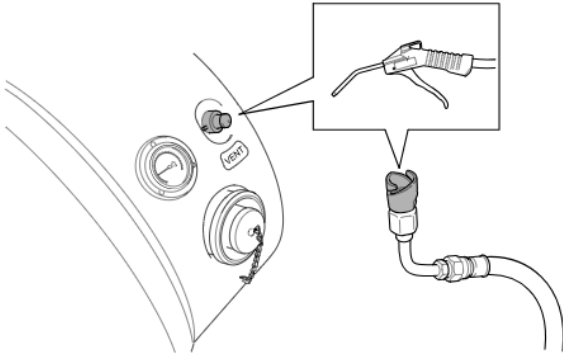
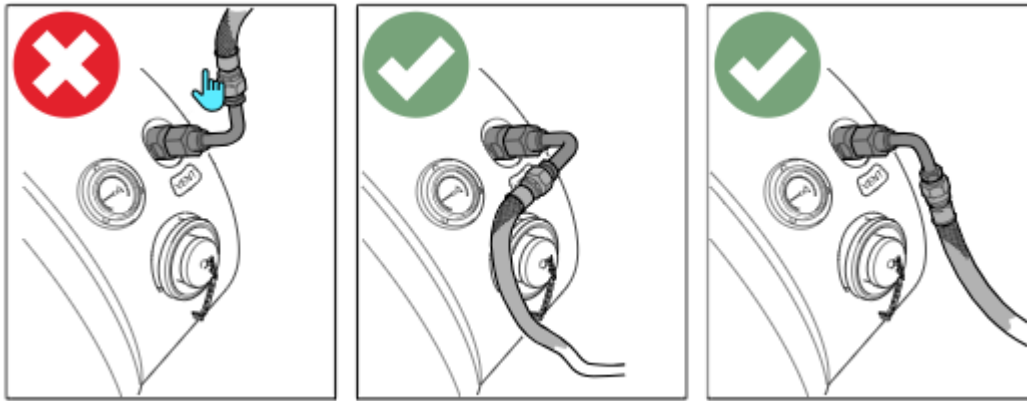
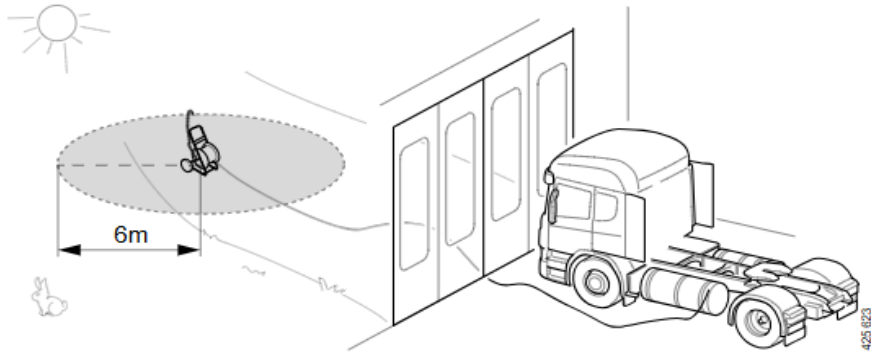

Chart-tank

3. Koble på evakuering sett (scania del nr:2987685)





5. Åpne de manuelle ventilene på tank/tankene

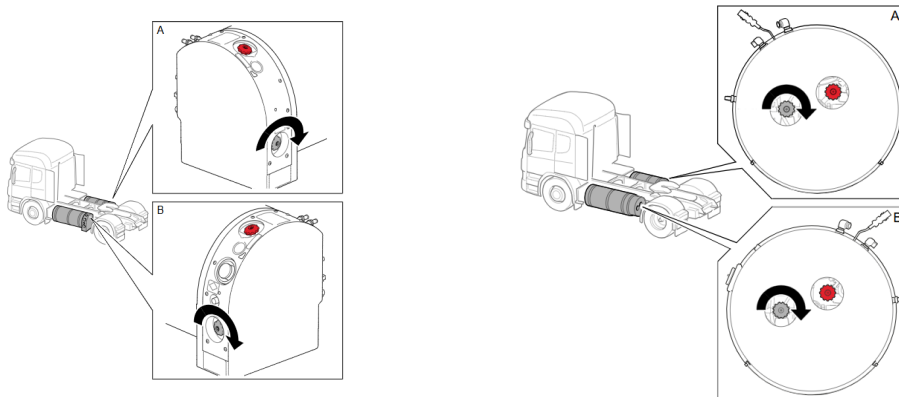



6. Heng på skilter på tanken som viser at ventilen er åpen

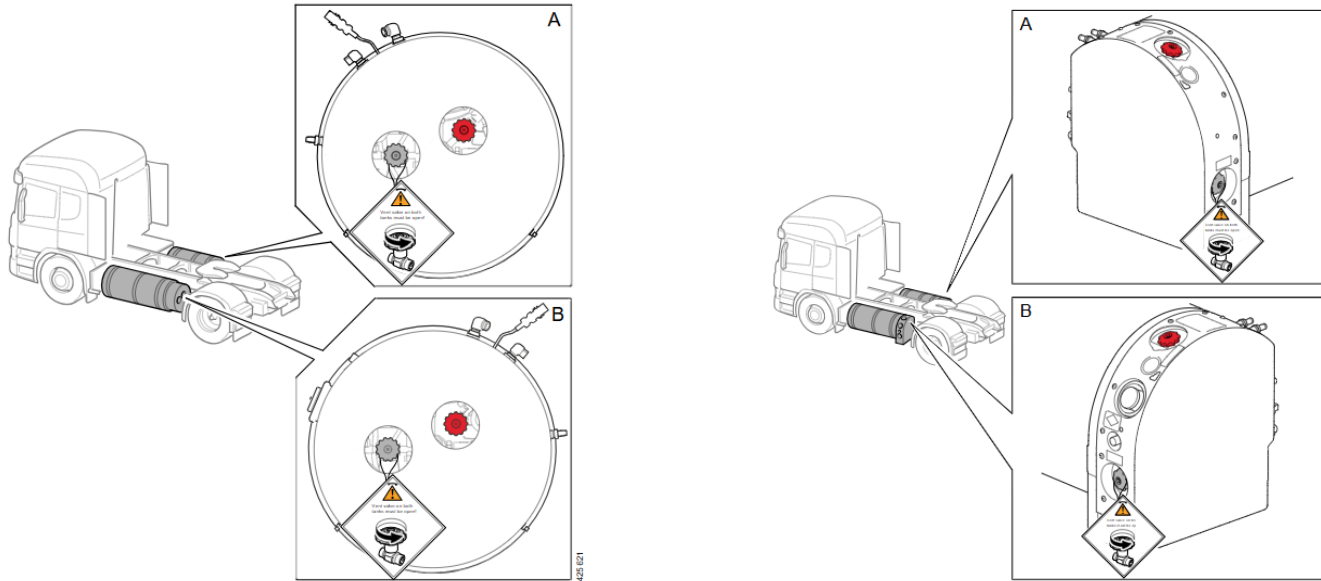

**Når bil er klar på verksted.
Steng ventilasjonsventilene og fjern utstyret.**



PTO

STYRING AV PTO MÅ GJØRES GJENNOM BILENS BCI SYSTEM

Forberedt for opp til 4 forskjellige PTO fra fabrikk

Fordon kan utrustas med kraftuttag eller elektrisk forberedelse for kraftuttag, från fabrikk.

Ett fordon kan utrustas med 1–4 kraftuttag.

Information om kraftuttag inklusive datablad och kalkylator för val av kraftuttag och hydraulpump finns på webbplatsen [Scania Truck Bodybuilder](#).

Tillval	Alternativ	Variantkod
Kopplingsberoende kraftuttag	EK730 ³	1298G
	EK740 ³	1298H
	EK750 ³	1298K
ED-kraftuttag	Förberedelse	4827A
	ED120P	4827B
	ED160P	4827C
	ED70P	4827D
	ED10R WBP1	4827E
	ED7R WBF3	4827G
	ED10R WBF4	4827H
EG-kraftuttag, toppmonterat	EG211F ^c	6389AA
	EG212F ^c	6389AB
	EABT MBF1 ^c	6389AC
	EG730P ^a	6389HA
	EG740F ^a	6389HB

- Inkluderer:
- BCI styresystem
- SOPS fil
- Bryter
- El. Knippe ferdig montert

Eller komplett med PTO



Elektrisk forberedelse

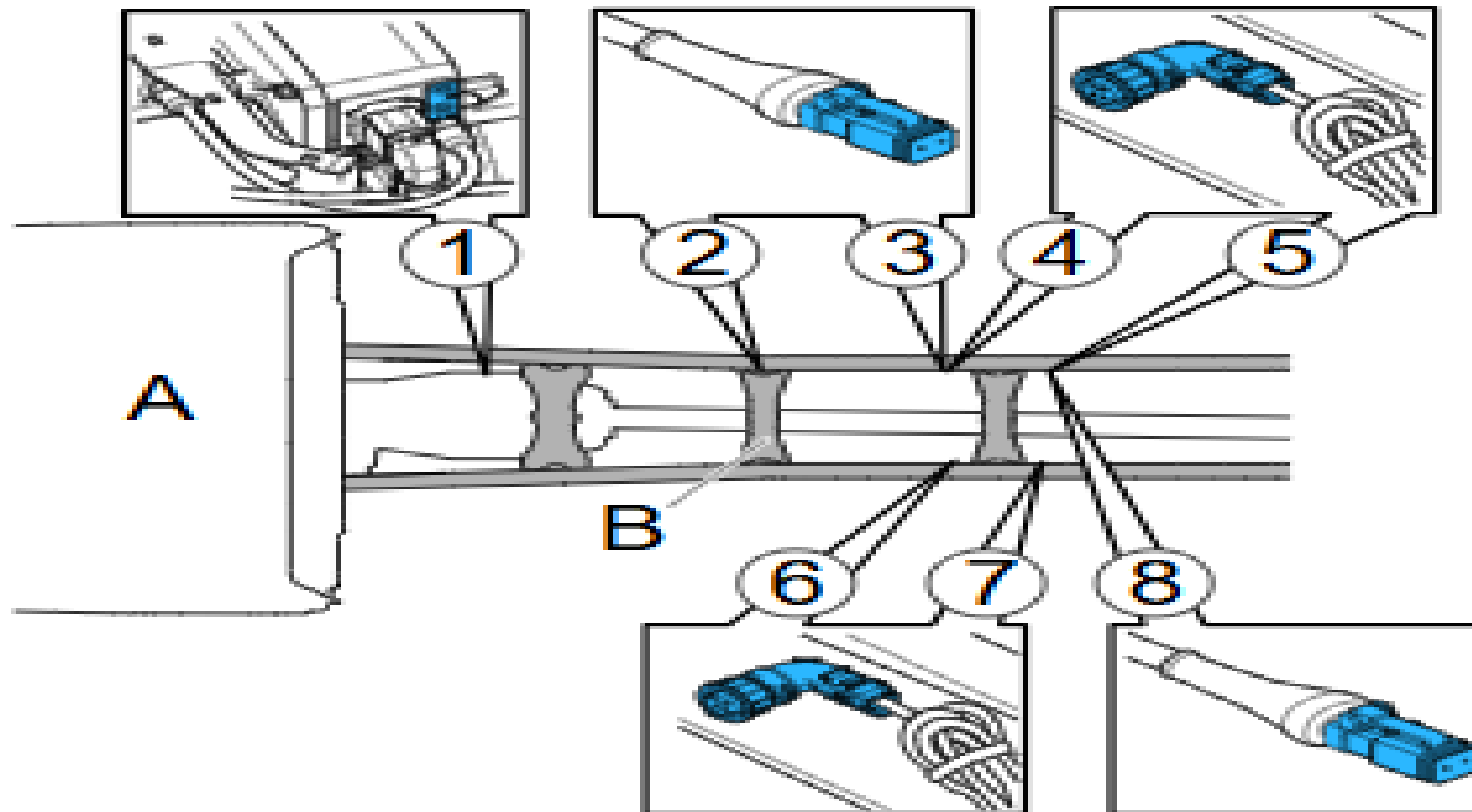

455 417



Fordeler med PTO styrt av BCI

- CAN kommunikasjon mellom bil og påbygg PTO aktivering/parametre
- Automatisk moment kompensasjon på motor ihht. belastning
- Beskyttelse/begrensning av moment og RPM. på PTO
- Sikkerhets funksjoner for hydraulikk system som temperatur, trykk etc.
- Statistikk på drifts timer med PTO
- Ubegrensede muligheter for varsling ved f. eks. Lys, lyd utvendig eller i instrumentbord. Eksempelvis hastighets begrense eller blokkere kranbil hvis kran ikke er pakket.



FRODE ANDREASSEN, PÅL RASTAD, KJETIL HANSEN & ROBERT STEEN

PÅBYGGERE BEHOV OG ØNSKER

SCANIA



Behov og ønsker fra påbyggere

- Hva savner dere fra Scania?
 - Kurs?
 - Materiell?
- Hva må Scania forbedre?
- Hva fungerer bra?



ROBERT STEEN

CHASSISTEGNINGER 2D / 3D + S-ORDRE

SCANIA



ICD/ICS 2.0 - OPPDATERT INTEGRASJON I SALGSPORTAL

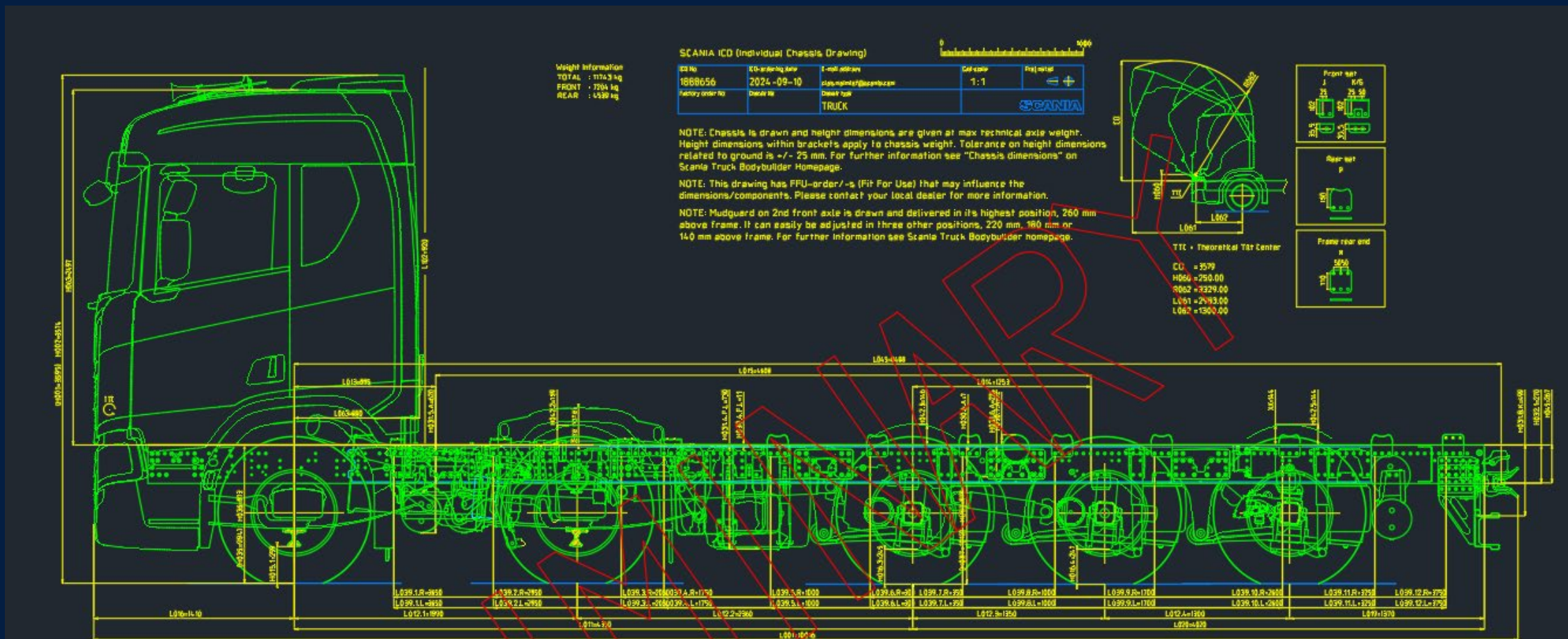



ICD/ICS 2.0-integrasjon i salgsportal

Hva:

- Et nytt ICD-system utvikles og vil bli introdusert i Sales Portal

Hvordan:

- Innføring av et nytt "brukergrensesnitt" i Salgsportal for forespurte tegninger for tilbud
- ICD-forespørselsknappen er fortsatt den samme

Hvorfor:

- Dagens ICD-system er vanskelig å forbedre og integrere i andre salgssystemer
- Behov for skybasert løsning for ICD-systemet i stedet for å bruke fysiske servere
- Raskere leveringstid for forespurte ICD-tegninger

Når:

- 21 nov 2024 lansering av ICD 2.0 i salgsportalen "ICD-tegninger for tilbud»

Hvem:

- Selgere og salgsstøtte. Ikke for påbyggere

Annen:

- Ingen endringer i tegningene: ICD 2D / 3D rammehulltegning
- Mindre endringer i ICS (spec. doc.)

ICD=Individuell chassistegning

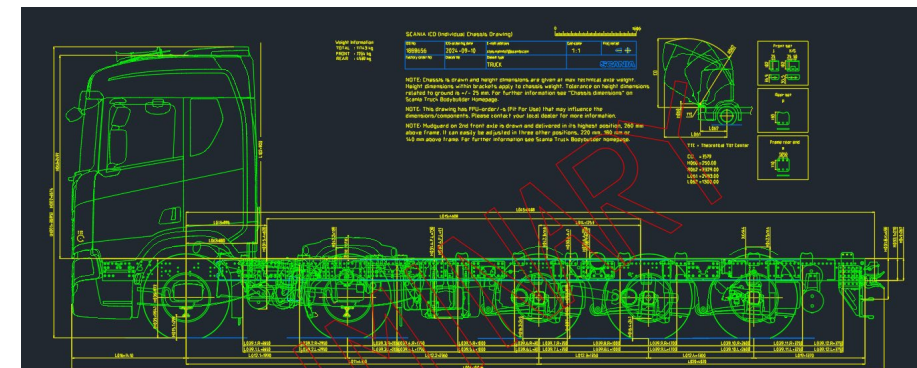

ICD/ICS 2.0 timeline

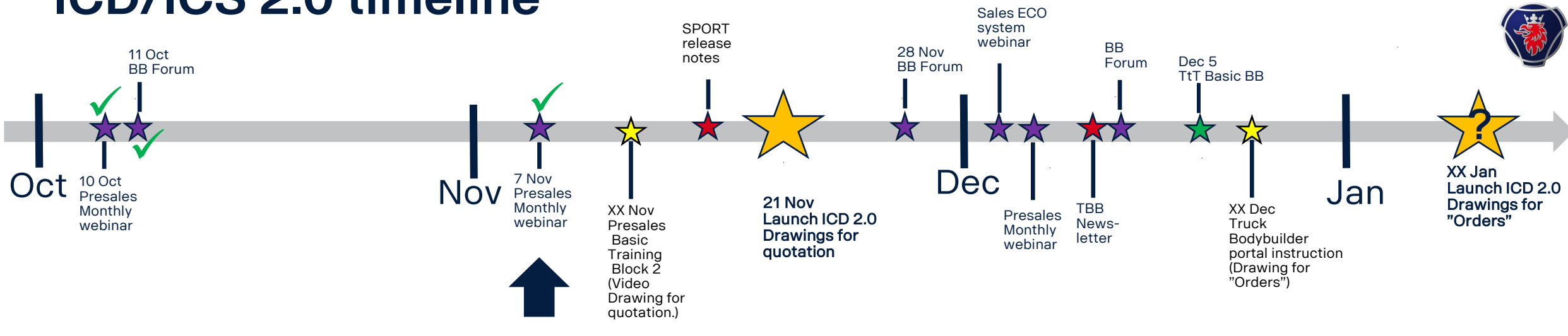

- Lansering av ICD/ICS 2.0 Tegninger for tilbud i Salgsportal. 21. november. 

- For selgere, salgsstøtte. Ikke for påbyggere.

- Lansering av ICD/ICS 2.0 Tegninger for "Ordrer" (Fabrikkordrenr, chassisnr). Dato TBD prel. januar 2025 

- For påbyggere, selgere og salgsstøtte.

- ICD/ICS 2.0 kommende opplæringer/instruksjoner

- Presales Basic Training Block 2 (Mitt kompass), lanseringsdato XX november. Lenke til introvideoen (3 min) 

- Truck Bodybuilder portal - ICD Tegninger for "Ordrer", lanseringsdato TBD 

- Informasjonskanaler

- Via Presales-webinarer, BB Forum, e-postutgivelsesnotater og TtT Basic (for BB) etc.   

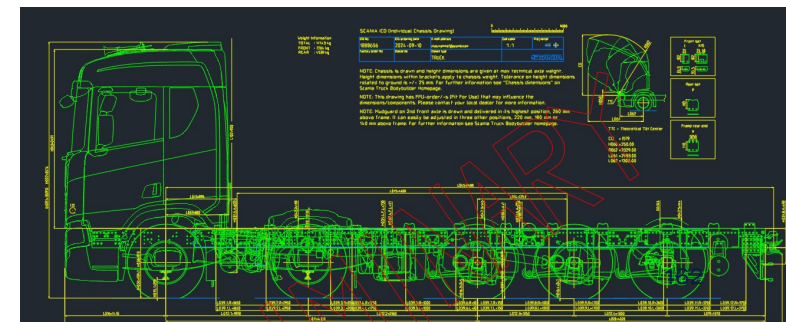

S-ordre



En kundetilpassing med endret design, eller ekstra funksjonalitet som ikke dekkes av det modulære systemet. S-ordre bruker Scania's modulære system i sin helhet. Variasjonen av S-ordre løsninger strekker seg fra å flytte komponenten på chassiset, til å legge til ekstra aksler for å skape nye konfigurasjoner.

Viktig for S-ordre:

- Alltid på forespørsel
- **Øyeblikksbilde A-ordensstruktur -> Modifikasjoner -> S-ordre**
- Gyldig i 3 måneder
- Montert på linje

Eks:

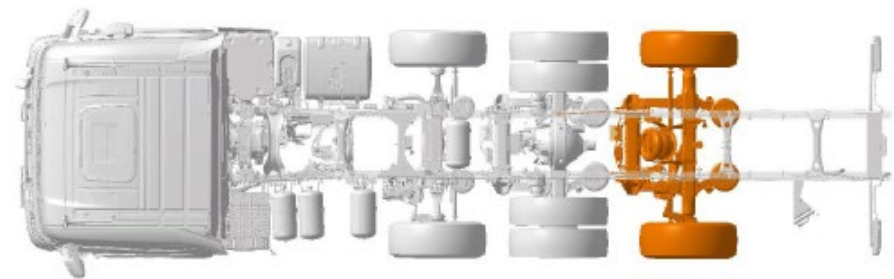
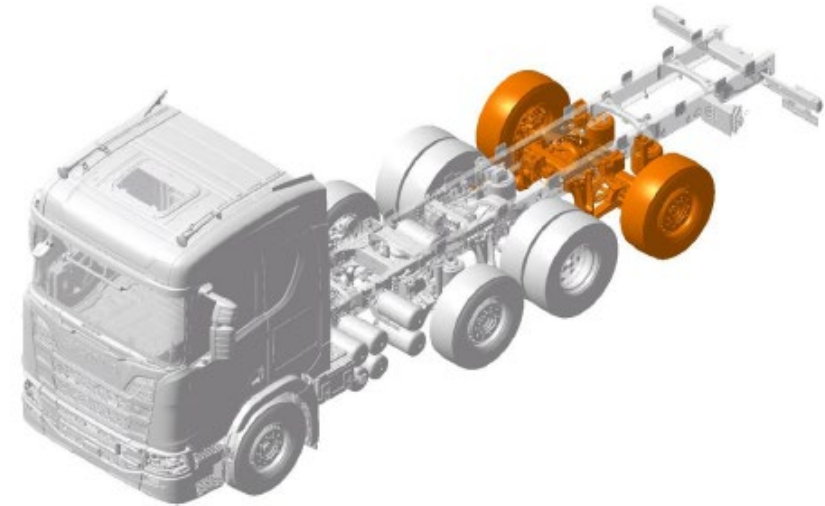
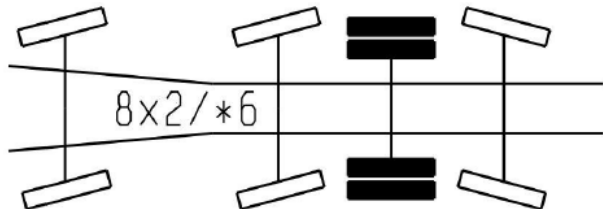

S-ordre



S-Ordre (Special Order)

En kundetilpasning med endret design eller ekstra funksjonalitet som ikke dekkes av det modulære systemet...

Eks:

S 650 B6x4*4HA

- S-hytte
- V8 650
- 4x4 + Styrbar boggi



Engine in AWD position

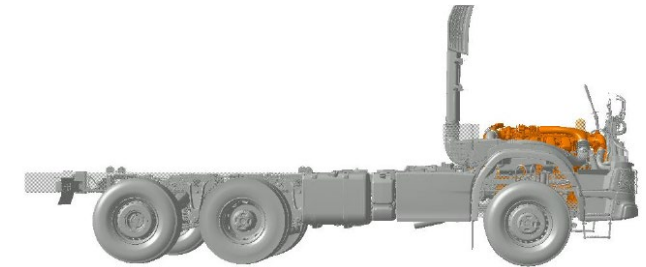

Cab

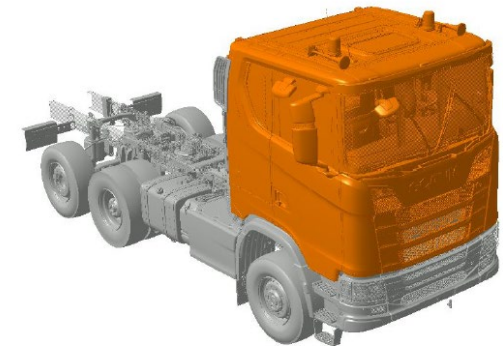

S-ordre



Informasjon er synlig i COW:

ORDREDETALJER			
Importør ID N	Ordredato / Kontrakt dato 2024-01-19 / 2024-01-19	Ordre Type Firm Urgent	NOS ordrenr 020240085
Forh.nr. 011 - Importør	Endret 2024-11-14 08:10:21	Typebetegnelse S 770 A6x4NB	AM Kontrakts nr. QMN8C64033-01
Selger ID 7833 - Robert Steen	Ønsket kundedato - DCD 20240406	Prod. opplegg 24042	Fabrikk ordrenr 1685498-001
Kundenavn Norsk Scania AS	Ønsket leveringsdato - DDD 2024-03-27	Produksjonssted Södertälje	ordrefil ID NO49362
Kundenummer NO-0000029	Foreløpig leveringsdato - PDD 2024-04-29 -2/+2	Prod. individual nr. 0010934712	Chassisnr 2202516
AM Tilbuds nr. QMN8CPYCR	Bekreftet leveringsdato - CDD 2024-05-06	Komplett chassisnr YS2S6X40002202516	FFU nummer
Tilbud beskrivelse CS23 202403.4 Karin Lundquist	Bekreftet leveringsdato 2 - CDD2 2024-06-20	Motornummer 1211641	S-ordre nummer 770767
Leveringsadresse SCANIA BILER A/S	Endringsfrist - SD 2024-01-23	Fabrikkfaktura nr	MCC Nummer
Leveringskode 720	Siste adresseendring - LAC 2024-03-22	Faktureringsdato fabrikk	Body forespørsel nummer
Leveringsadresse by Vojens	Ferdig Dato 2024-06-10	VAT Number Seller SE556084097601	
Land for levering fra fabrikk Denmark	Dato fra fabrikk 2024-06-14	VAT Number Buyer DK35452249	
	Faktisk leveringsdato 2024-06-20		
Nei - Order change not allowed when order is locked			

Basic info om S-ordre er beskrevet:

FFU, MCC, S-ORDER & BUS BE OM INFORMASJON NUMMER
S-ordre nummer 770767: A6x4NB 3350mm CS23H with vertical exhaust LDTA 21t
MCC Nummer U:



Når er chassistegninger tilgjengelige?

- Midlertidige chassistegninger kan bestilles av selger **før** bestilling.

Kun midlertidige chassistegninger er tilgjengelige pga:

- Spesifikasjon kan endres fram til den låses i produksjonen på fabrikk
 - 8 uker

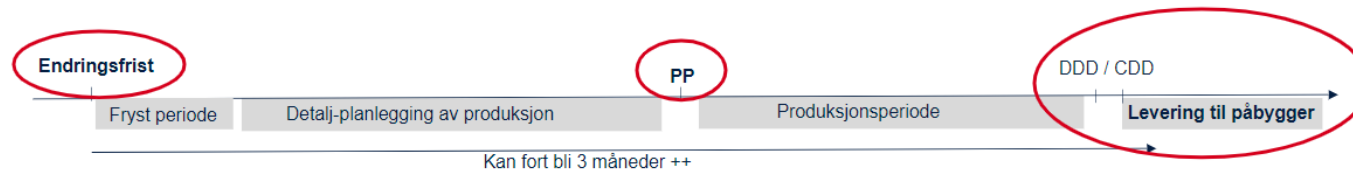

- NB; Større endringer kan flytte produksjonsperiode pga ledig kapasitet
- S-ordre vil bli synlig på tegning / COW, etter at chassis er låst i produksjon
- Ved spesielle tilfeller, så kan vi forespørre fabrikk om chassistegning med S-ordre
 - Dette er unntaksvis, og må forespørres inn fra importør via FRAS!



ROBERT STEEN

CHASSIS FORBEREDELSE

SCANIA



Forberedelser på chassis

- Ønskemål;
 - Økt kvalitet på sluttprodukt
 - Samme standard (løsning) som gjøres hver gang
 - Enklere å feilsøke
 - Kortere ledetid
 - Enklere reservedelsløsning
 - Kostnadseffektivt for kunde
 - Større margin for både Scania og påbygger
 - Plug and play



SCANIA

TIMBER TRANSPORT

BODYBUILDING MADE EASIER!

Tailormade for your application with best preparations available.





1

The bodybuilding process is a shared process. By involving all stakeholders from the beginning, we secure quality, reduce lead time and eliminate waste.



2

The early stage is very important. Here we make sure the chassis is equipped with the right preparations and has an optimized bodywork interface.



3

Whenever information is required, Scania truck bodybuilder portal has everything you need.

4



With good planning the chassis and bodywork can be produced in parallel to shorten lead time in the build process.

5

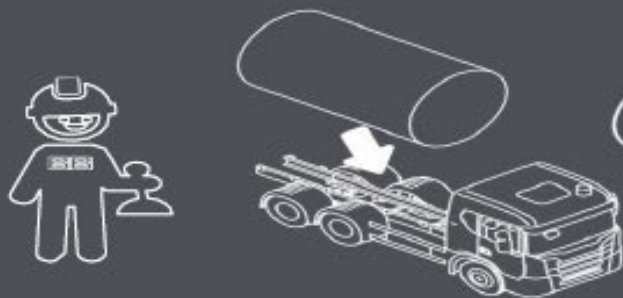

When the chassis arrives at the bodybuilder, fitting the bodywork is just plug and play.



This process ensures that we deliver the highest quality, on time, at the right cost. And the customer will take delivery of the best truck in the world.



TILLVAL

ANVÄNDINGSOMRÅDEN

VERKTYG FÖR KAROSSALTERNATIV

ANVÄNDINGSOMRÅDEN

BEV

FIRE ENGINE

FLYGPLANSTANKNING

Truck specification
Chassis: L 260 B4x2NB
Cab: CL20L

Truck specification
Chassis: S 400 B6x2LB
Cab: CS20H

Truck specification
Chassis: P 430 B4x2VA
Cab: CP31L

Truck specification
Chassis: P 230 B4x2VZ
Cab: CP1ML

PDF

Truck specification
Chassis: S 400 B6x2LB
Cab: CS20H

Truck specification
Chassis: P 430 B4x2VA
Cab: CP31L

Truck specification
Chassis: P 230 B4x2VZ
Cab: CP1ML

PDF

Truck specification
Chassis: P 430 B4x2VA
Cab: CP31L

PDF

LIVESTOCK TRANSPORT

Truck specification
Chassis: S 400 B6x2LB
Cab: CS20H

PDF

FLAT BED WITH CRANE

Truck specification
Chassis: S 400 B6x2NB
Cab: CR20H

PDF

LASTVÄXLARE

Truck specification
Chassis: P 230 B4x2VZ
Cab: CP1ML

PDF



Truck specification

Chassis: R 560 B6x4NB

Cab: CR20H

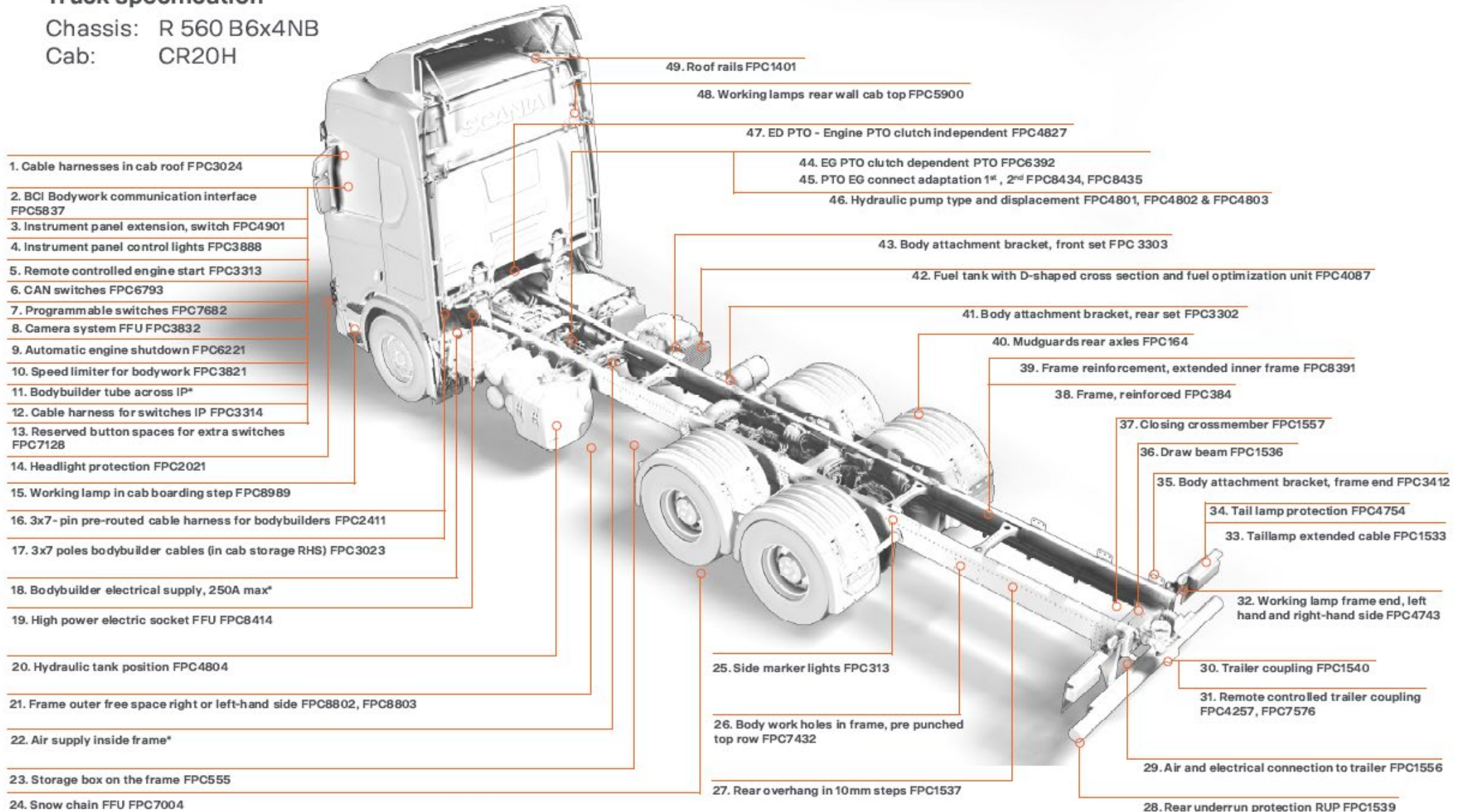

*Always on truck

Bodybuilding Made Easier – Additional Information

More options and detail information can be seen in TBB portal



1	Extra harnesses for bodybuilder installed in cab roof (FPC3024)	27	Scania can deliver a perfect adapted overhang to every bodywork within 10 mm steps (FPC1537)
2	BCI is a programmable interface which is facilitating communications between truck and bodywork. The BCI can be programmed with advanced logics for safety and other operational functionality in the bodywork (FPC5837)	28	Rear underrun protection available in 3 different styles/executions, that meets UN ECE R58 with the supplement 03 (FPC1539)
3	An extra panel with space for extra switch attached to the instrument panel (FPC4901)	29	Trailer connections can be specified in Continental or Nordic versions (FPC1556)
4	There are many options for the bodywork to provide the driver with information, 8 lamps, sound and display messages in the instrument cluster (FPC3888)	30	A towing unit (coupling) is required in order to tow a trailer after the truck. It is fitted in the truck's draw beam (FPC1540)
5	Preparation for engine start via bodywork communication interface (BCI) (FPC3313)	31	Remote control of trailer coupling using air servo which is fitted at the rear section of vehicle (FPC4257 & FPC7576)
6	Spaces in the instrument panel are reserved for extra switches that are programmed in the BCI control unit (FPC6793)	32	Work lights aimed backwards on the left and right-hand sides below the cab. Controlled with a switch on the door panel (FPC4743)
7	Programmable switches makes it possible to program different switches via Scania bodywork interface configuration tool (BICIT) (FPC7682)	33	The cables to the rear lights can be specified in standard length or extended by 600 mm or 1200 mm (FPC1533)
8	Scania can offer many different options from factory for front and rear-view cameras to suit a variety of applications (FPC3832)	34	The robust rear light protection is suitable for trucks operating in tough conditions (FPC4754)
9	The engine is switched off automatically after a certain period of running at idling speed (FPC6221)	35	Scania can offer many different body attachment brackets to suit a variety of applications. The bodywork attachment is bolted into the upper row of holes on the chassis frame. The rear end of the chassis frame comprises the area from where the rear section ends to the rear edge of the chassis frame (FPC3412)
10	The vehicle can have two additional speed limits that are programmed into the BCI control unit (FPC3821)	36	Scania draw beams have hole layouts that allow a draw beam, under-run protection and body adaptation brackets to be mounted in a wide variety of positions (FPC1536)
11	All trucks are supplied with an empty tube inside the instrument panel, dedicated for the bodybuilder	37	Vehicles that do not have draw beam or any other types of crossmember at the rear of the frame must be fitted with a closing crossmember (FPC1557)
12	Extra harness for additional switches (FPC3314)	38	The rear section of the frame is reinforced to enable it to carry a rear-mounted crane (FPC384)
13	Space for extra switches can be reserved for custom adapted functions, the physical connection between switches and bodywork console must be performed separately (FPC7128)	39	Extended inner frame reinforcement towards the rear end of the frame is to increase torsional rigidity and section modulus for the rear overhang (FPC8391)
14	The headlamp is protected by a steel grille (FPC2021)	40	Mudguards made of hard plastic designed for the rear axle/axles (FPC164)
15	LED working lamps that are secured to the front right, left-hand or both side at the boarding step of the cab in order to illuminate the area adjacent to the truck (FPC8989)	41	The rear section comprises the area from where the front section ends to 300-600 mm from the rear edge of the chassis frame (FPC3302)
16	Pre-routed cable harness from the bodywork's central electric unit in the cab to the chassis frame which makes it easier for the bodybuilders to have external access to the bodywork's central electric unit (FPC2411)	42	New D-shaped fuel tank range provides increased fuel capacity, reduced weight, improved robustness and easier serviceability. A Fuel optimization unit (FOU) is attached to the new D-shaped fuel tank to ensure that as much fuel as possible can be utilized from the tank (FPC4087)
17	Three 7-pin extension cable for connecting equipment on the frame in three different lengths; 2m, 8m or 12m (FPC3023)	43	The front section of the chassis frame comprises the area from the center of the foremost front axle to approx. 3,000 mm behind the front axle (FPC3303)
18	All trucks are supplied with a dedicated electrical output, located behind the mudguard of the 1st front axle	44	Gearbox mounted PTO are clutch dependent. These PTO can only be used when the clutch pedal is released (FPC6392)
19	The electrical socket allows a semi-trailer to be connected for battery charging or use of tail lift (FPC8414)	45	Selection of output flanges for PTO. If a double output PTO is specified, different flange types can be chosen for lower and upper connection (FPC8434, 8438)
20	Hydraulic tank from factory in addition determining which side the hydraulic tank should be located in relation to driving direction as well as front or rear of chassis frame (FPC4804)	46	Hydraulic pump type and volume can be selected to fit different needs/applications (FPC4801, 4802, 4803)
21	Possibility to specify different types of free space on the chassis frame (right- or left-hand side). This will facilitate the bodybuilding and enable the possibility to manage the weight distribution (FPC8802, FPC8803)	47	Engine mounted PTO located at the rear end of the engine (FPC4827)
22	A dedicated outlet for bodybuilder who needs to have air for bodywork is included on every chassis. This is the one and only place allowed to connect air supply to bodywork	48	The work light consists of two LED headlamps fitted on the left and right-hand sides of the rear cab wall (FPC5900)
23	Available in three different length FPC555	49	The roof rails are in aluminum which simplifies the fitting of an air deflector, roof rack and other extra equipment (FPC1401)
24	Snow chains are secured over the tires and prevent the wheels slipping on snow and ice (FPC7004)		
25	Increase road safety by making it easier for other road users to notice the vehicle, available in fix or temporarily fitted (FPC313)		
26	Frame prepared with an upper row of holes. The holes are spaced at 50 millimeters and are used to attach the bodywork to the frame of the truck (FPC7432)		



BODYWORK PROGRAMMABLE SWITCHES

Instrument panel can accommodate up to 10 CAN pushbuttons or 15 electrical switches depending on vehicle configuration.

- Bodywork programmable switches preparation
FPC 7682A

- Pushbutton BCI reserved quantity
2-10
FPC 6793

- Switch positions BWE reserved quantity
1-15
FPC 7128

[Learn more](#)



Forberedelse må være lønnsomt i forhold til kostnad;

- Scania får et billigere påbygg i forhold til investering / kostnad på forberedelse.
- Påbygger får økt volum / sparer tid og penger.
- Krever god og tidlig dialog mellom selger, påbygger (og kunde).



SCANIA



Forberedelser på chassis - eksempler

- Brøytelysforberedelse

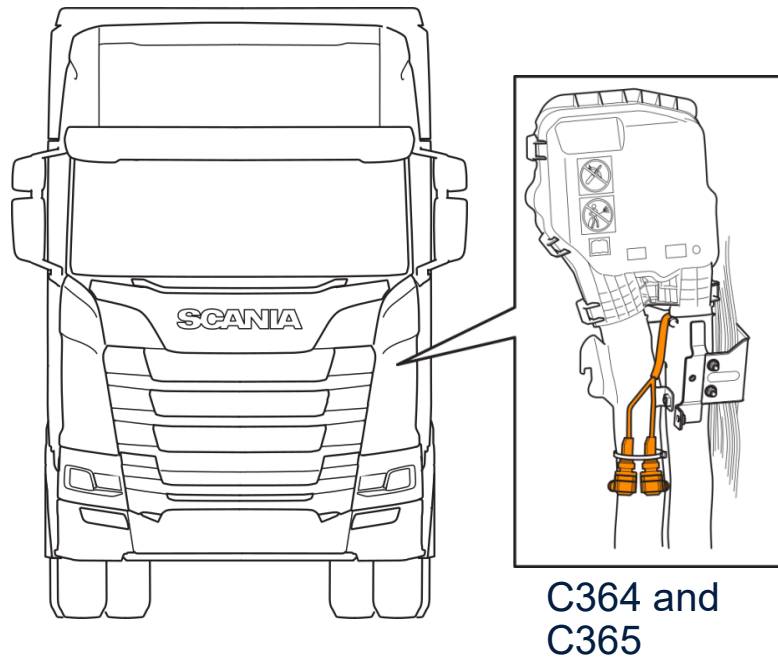



Forberedelser på chassis - eksempler

- Forberedelse for varsellys på tak

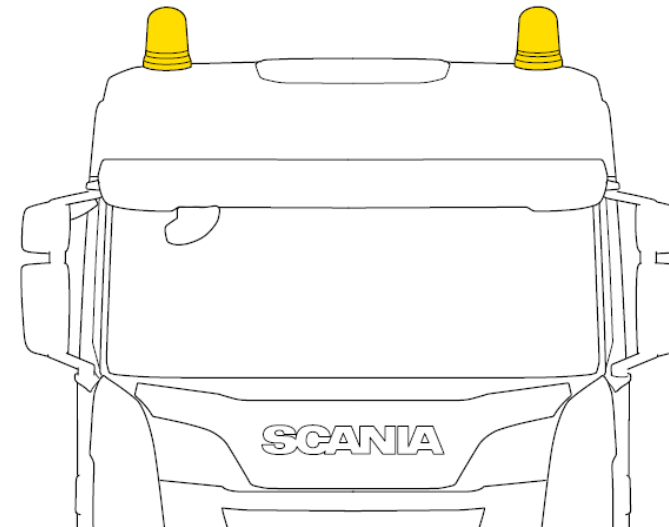
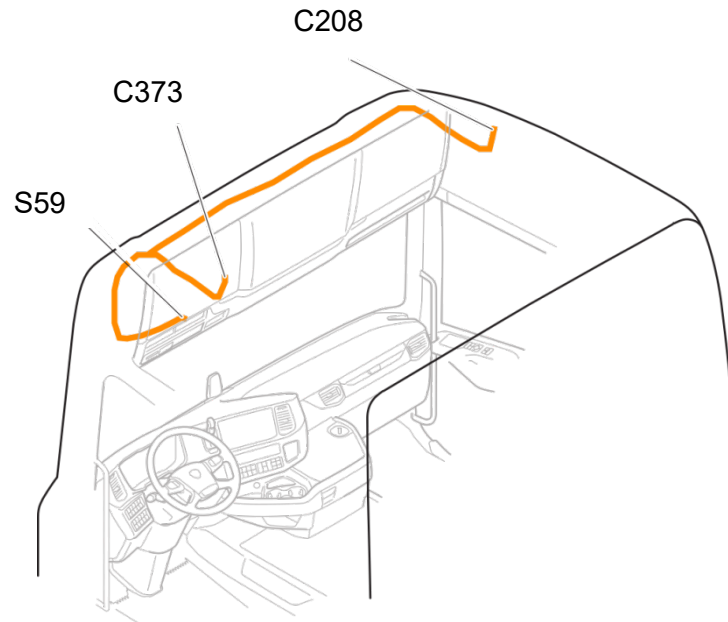



Forberedelser på chassis - eksempler

- Arbejdslys bak på chassis

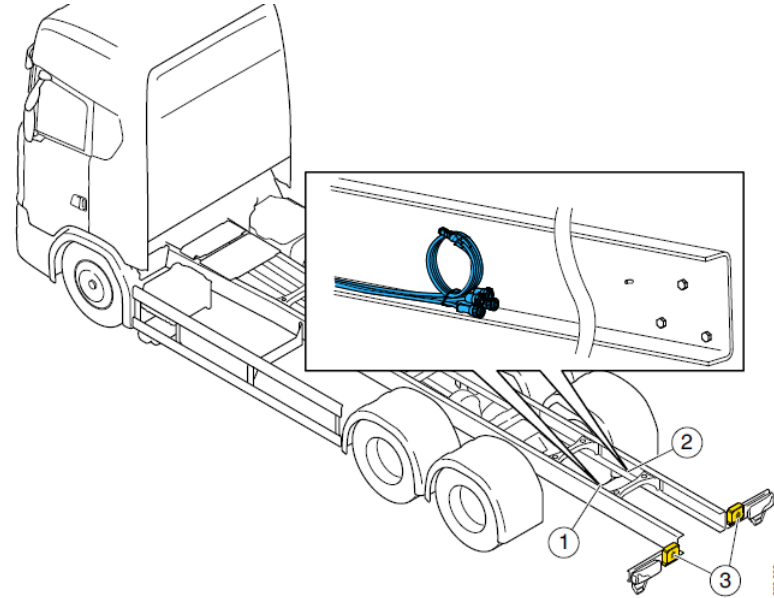

B - LH side prep

E - LH side

C - RH side prep

F - RH side

D - LH+RH side prep

G - LH+RH side



Forberedelser på chassis - eksempler

- Forberedelse for arbeidslys nede bak førerhus

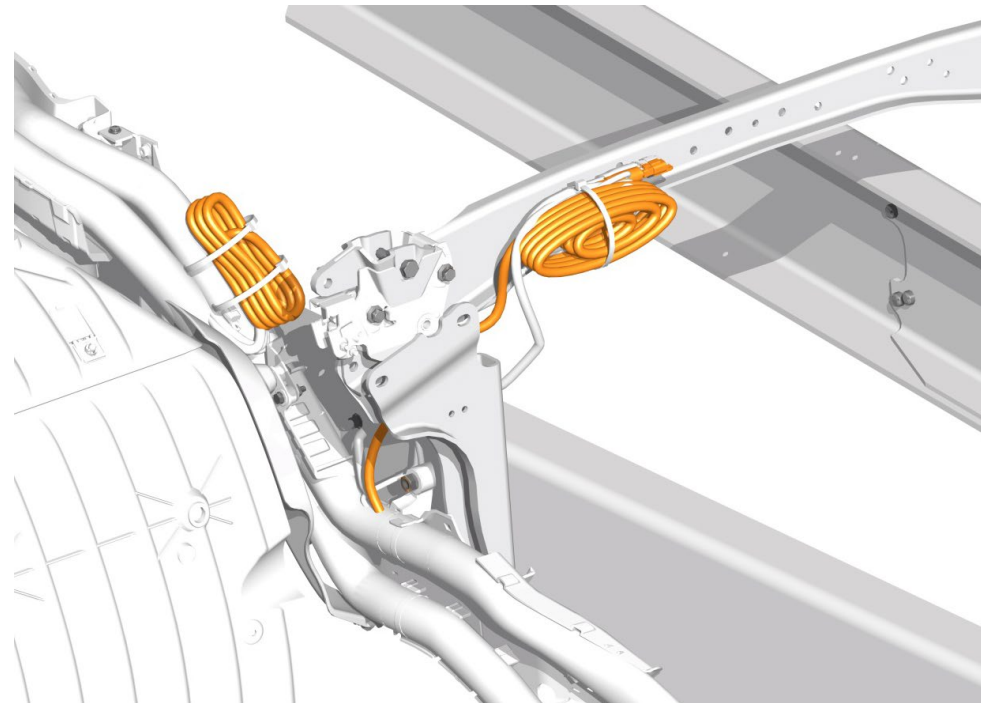



Forberedelser på chassis - eksempler

- Forberedelse bakløfter

Brytere i instrumentpanelet, og klargjort ledningsopplegg for bakløfter, belysning i lasterommet og posisjonslys på skaptaket.

Forbindelser som illustrert under:

C157: 1-pinners kontakt for strømforsyning.

C152: Jordingsledning

C158: Forbinder skapbelysning og høyre og venstre posisjonslys som er rettet bakover og montert på toppen av skapet.

C159: Forbinder hekkløfteren.

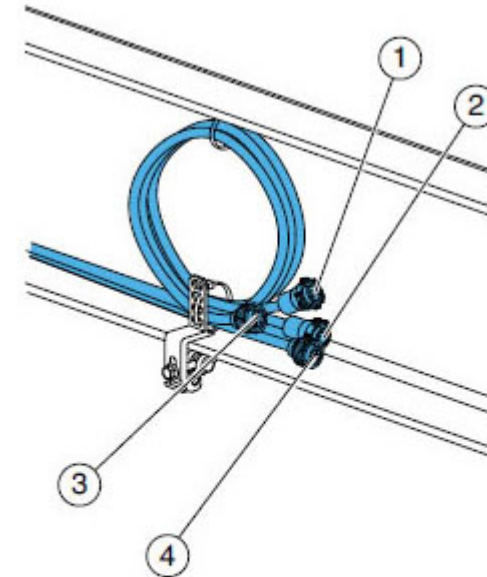

1. Connector C157
2. Connector C152
3. Connector C158
4. Connector C159



Forberedelser på chassis - eksempler

- Forberedelse for tippbil





Forberedelser på chassis - eksempler

- Forberedelse for 4 stk brytere

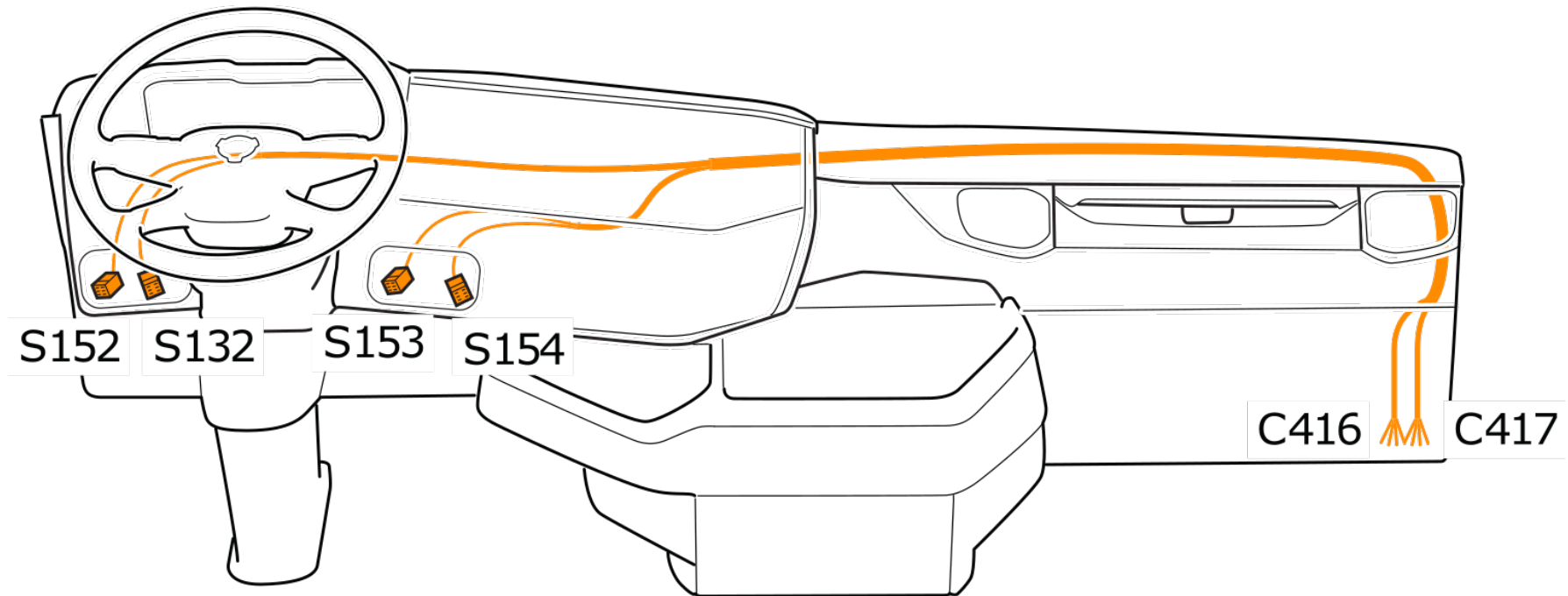



Forberedelser på chassis - eksempler

- El-rør i dashboard

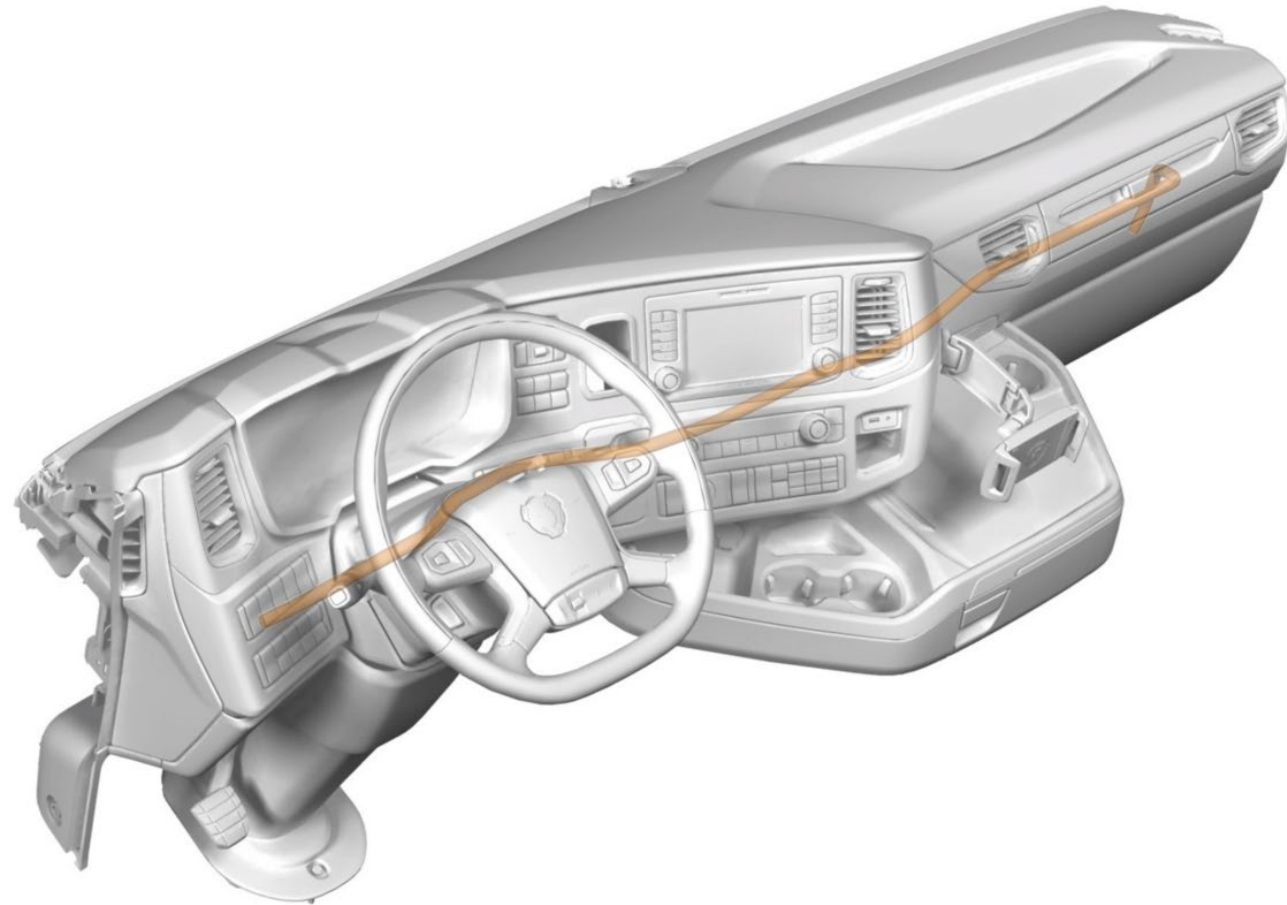



Forberedelser på chassis - eksempler

- Forberedelse for kabel til frontpanel

5 ledninger 4 mm²
5 ledninger 1.5 mm²
2 vridde ledninger for CAN-kommunikasjon

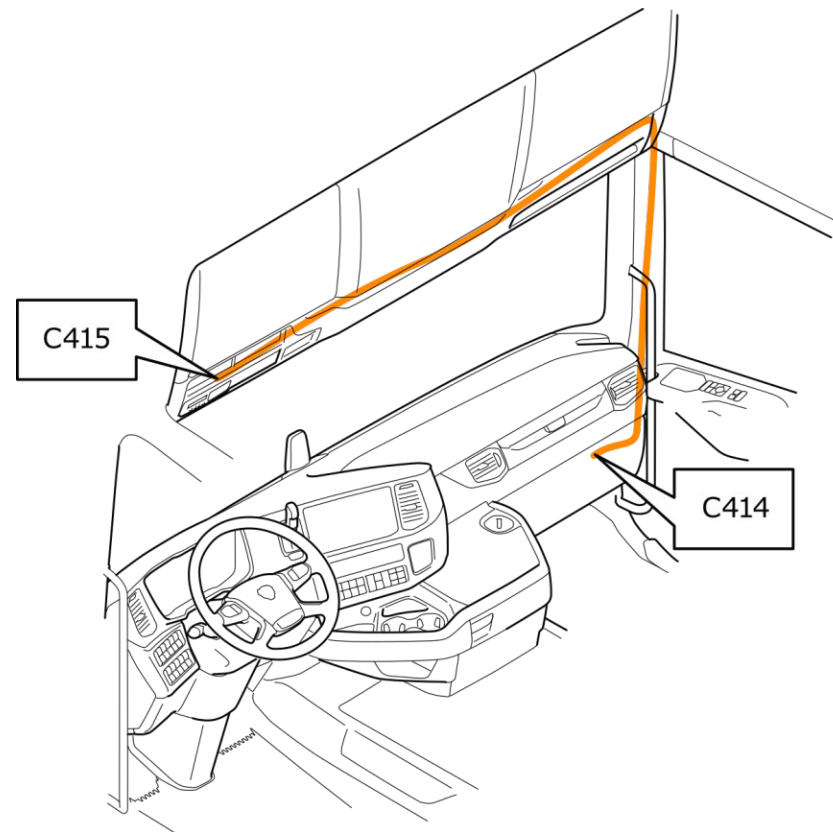



Forberedelser på chassis - eksempler

- Påbyggerkabel

- 1 DIN connector: C487
- 2 DIN connectors: C486 & C487
- 3 DIN connectors: C486, C487 & C488

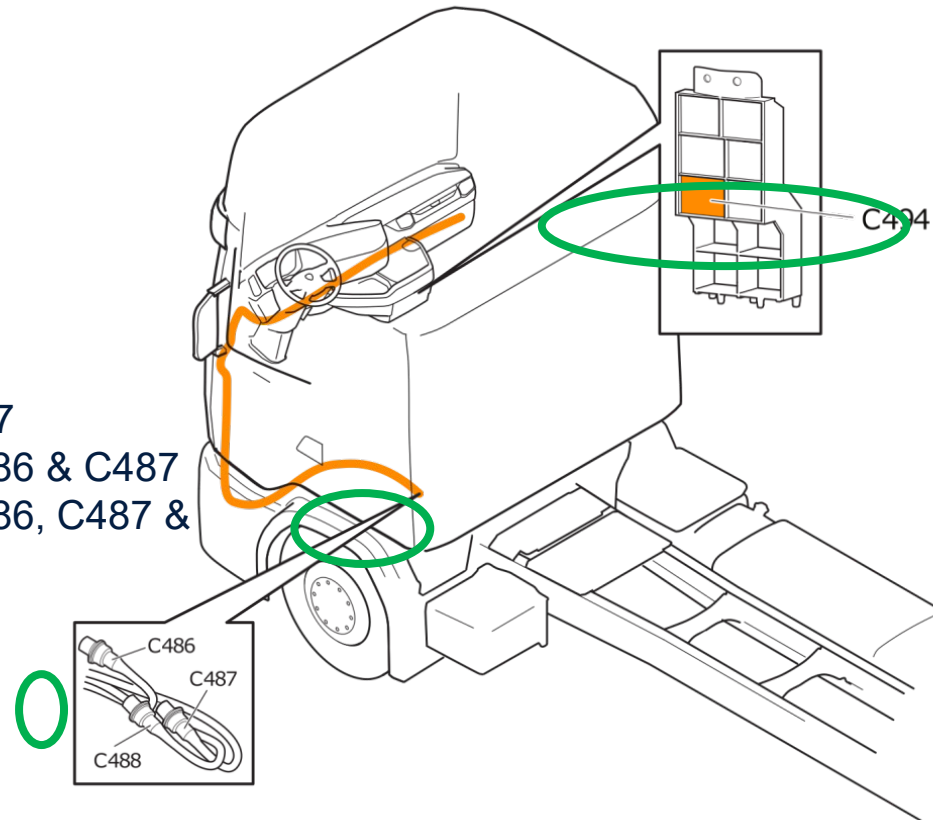



Forberedelser på chassis - eksempler

- Påbyggerkabel forlængelse

Ligger i førerhus

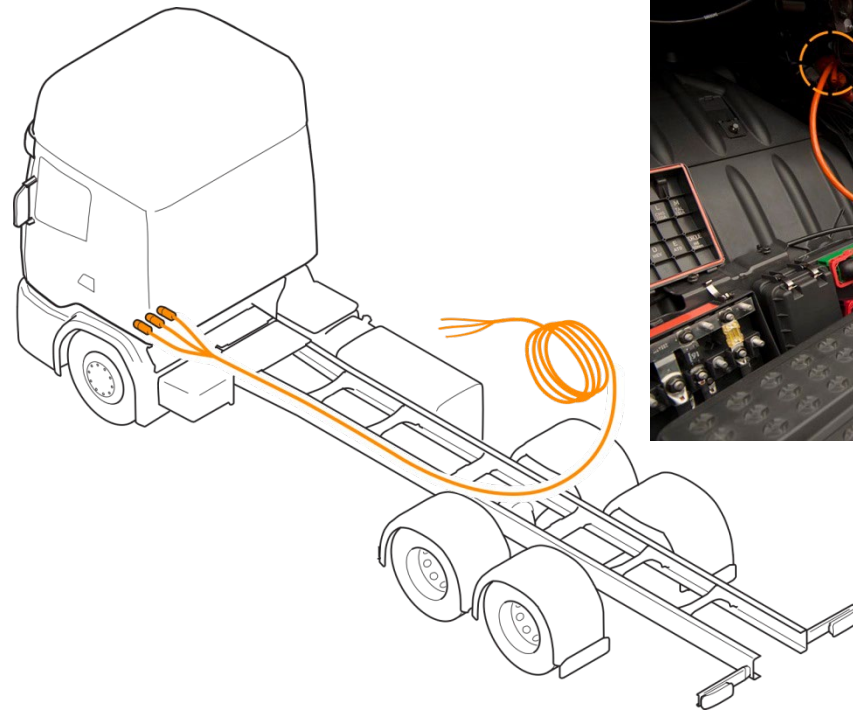

2
8
eller 12 meter





Forberedelser på chassis - eksempler

- Tilpasset rammelengde

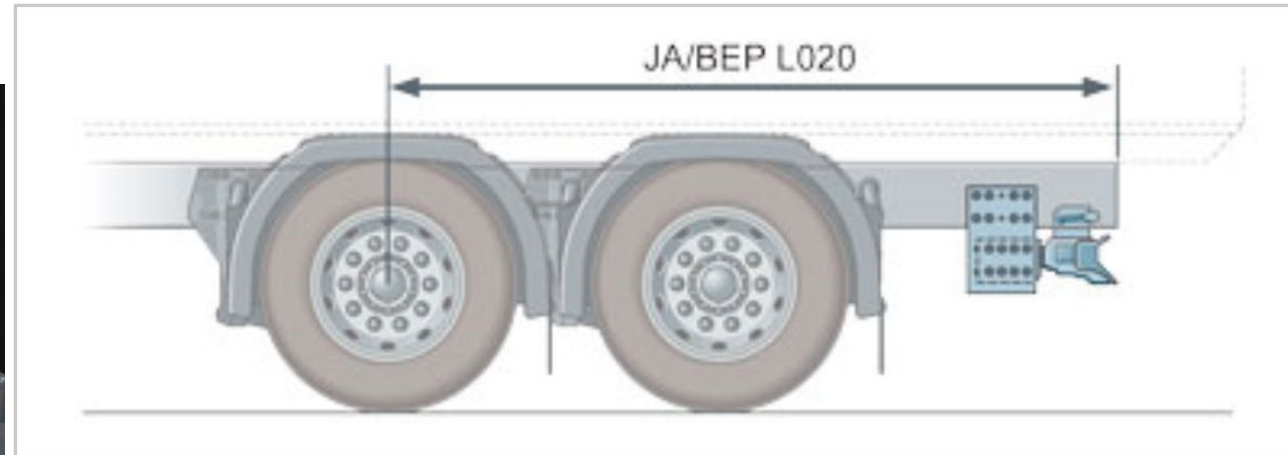
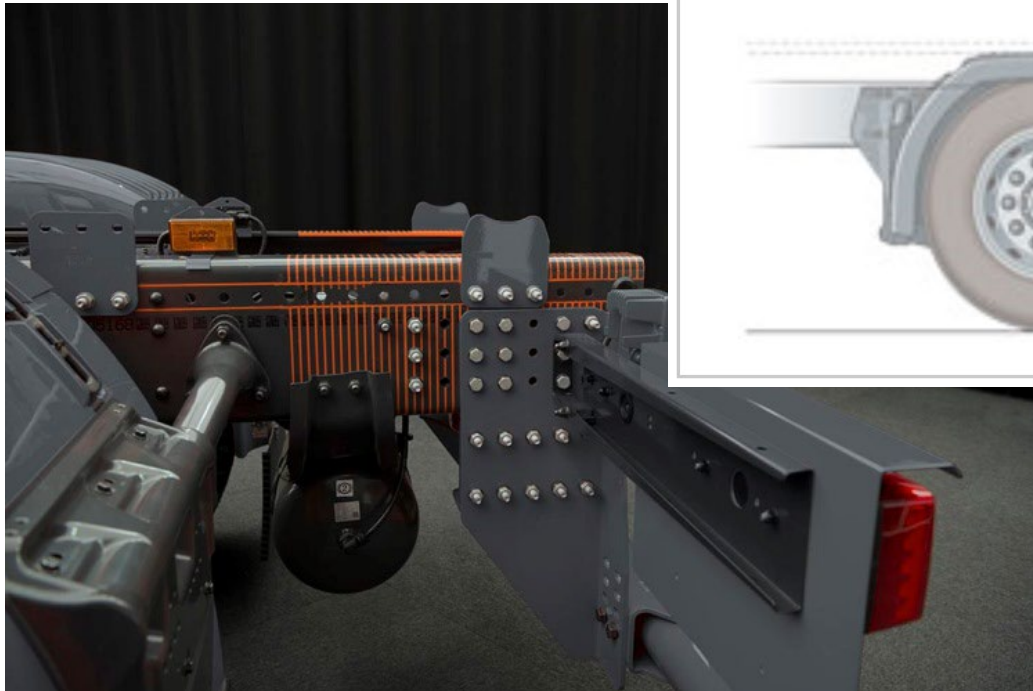



Forberedelser på chassis - eksempler

- Brakett for plogfeste

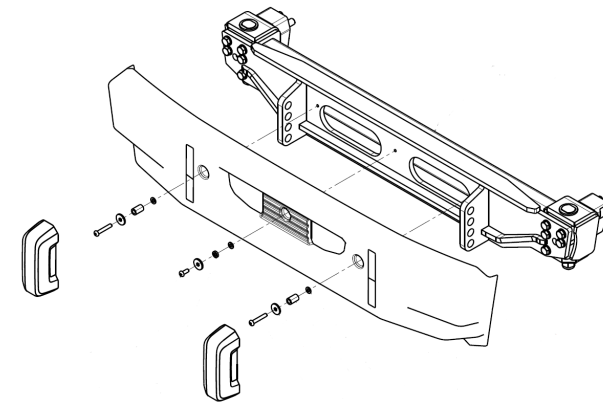
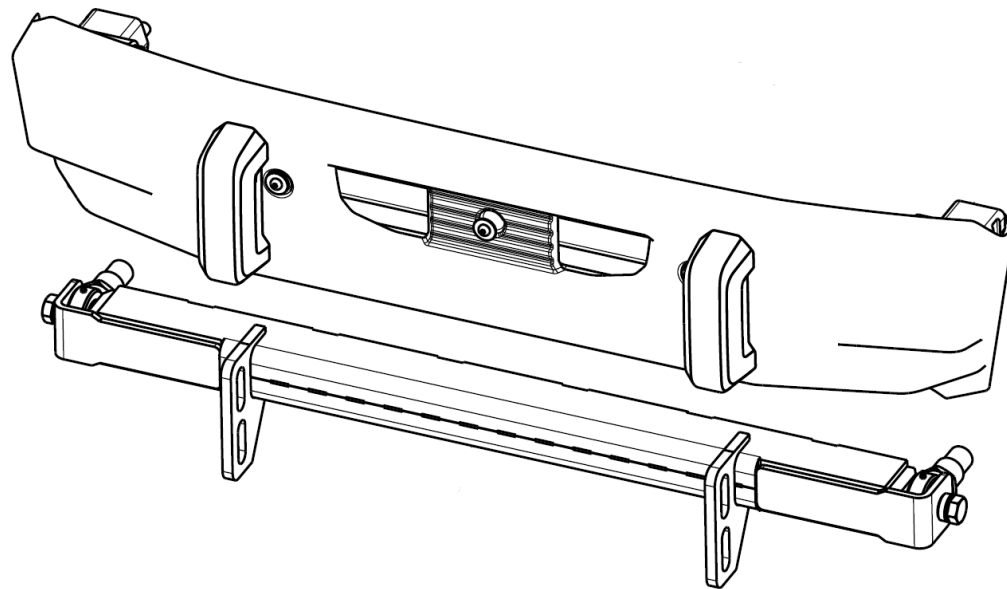



Forberedelser på chassis - eksempler

- Forberedelse for støtteben

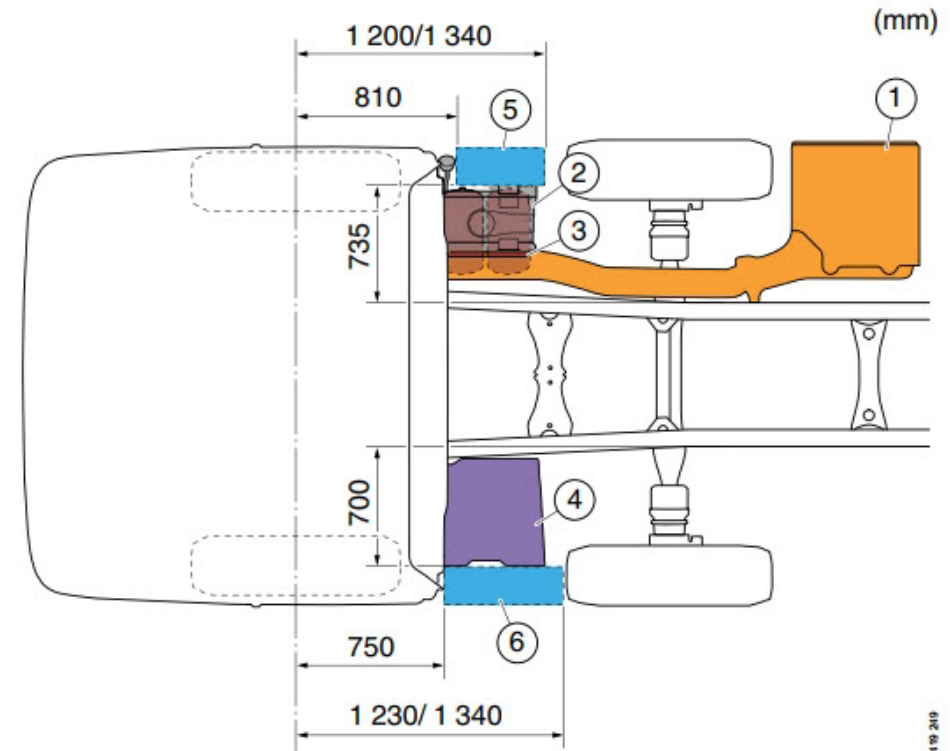
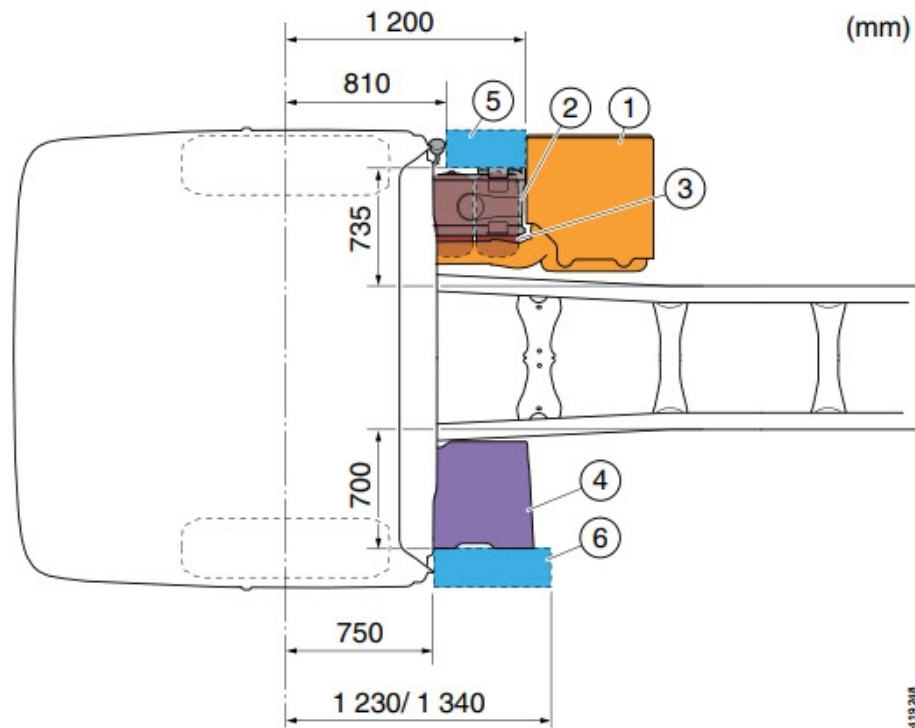



Forberedelser på chassis - eksempler

- Rammefester

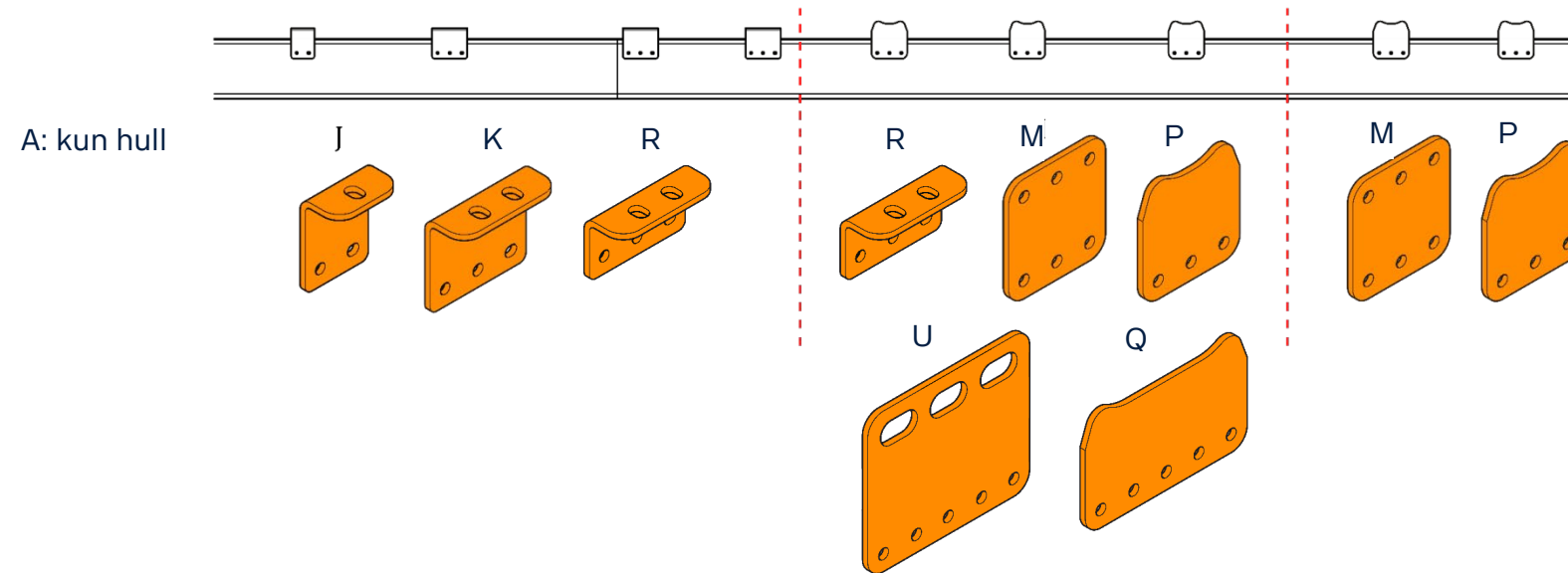



Forberedelser på chassis - eksempler

- Rammefester

Dere vet om denne?

8 mm ± 0.1 mm plate



Kombinert feste og brakett



FRODE ANDREASSEN, PÅL RASTAD & ROBERT STEEN

SCANIA TBB BRUK OG PÅLOGGING

SCANIA



Bodybuilder konto- og passordinformasjon

Scania sine påbyggere (Scania TBB) krever nå pålogging for å se innhold:

<https://bodybuilder.scania.com/>

Alt er personlig, og må ordnes for hver enkelt bruker. Vi trenger 4 grunnleggende data;

- Firma
- Navn
- Mailadresse
- Mobilnummer

Merk at mailadresse og mobil må være personlig. Fellesmail o.l. går ikke!

WELCOME TO SCANIA BODYBUILDER PORTAL





Bodybuilder konto- og passordinformasjon

Nytt utseende (layout) på hjemmeside

Uten pdf-dokumenter. Man må evt ta utskrift av hvert tema.

SCANIA | TRUCK BODYBUILDER

Search

HOME REQUIREMENTS INSTRUCTIONS DRAWINGS AND 3D TOOLS AND SERVICES FACTORY-FITTED OPTIONS TRAINING NEWS LOCAL INFORMATION HELP

INSTRUCTIONS: LPGRS - SERIES

Chassis number filter under construction

Language
Select Language

Filters

- Allmän information
- Fordonskomponenter och system
- Elektriska system
- Påbyggnadsarbete
- Påbyggnadsinfästningar och hjälpramar

Påbyggnadsarbete / Påbyggnadsinfästningar och hjälpramar

Val av hjälpram och infästning

2023-12-19

Allmänt

Det här avsnittet beskriver Scanias generella rekommendationer för dimensionering och utförande av hjälpramar.

Mer information finns i följande avsnitt:

- Påvoanadsfästen och hålbilder



Bodybuilder konto- og passordinformasjon

Hvis man ikke finner det man leter etter i menyfeltet, så anbefaler vi søkefeltet

The screenshot shows the Scania Bodybuilder website interface. At the top left is the Scania logo and 'TRUCK BODYBUILDER'. To the right is a search bar with the text 'Search' and a magnifying glass icon, highlighted with a red border. Below the search bar is a navigation menu with links: STARTSIDA, KRAV, INSTRUKTIONER, RITNINGAR OCH 3D, VERKTYG OCH TJÄNSTER, FABRIKSMONTERADE TILLVAL, UTBILDNING, NYHETER, LOKAL INFORMATION, and HJÄLP. Below the menu is a dark blue bar. The main content area has a red heading: 'Chassis number filter under construction'. Below this is a sidebar with a 'Language' dropdown menu and a 'Filters' section. The 'Filters' section has two icons: a document and a truck. A large red arrow points from the text on the right to the truck icon. Below the filters is a list of menu items: '- Allmän information', '- Fordonskomponenter och system', '- Elektriska system', '- Påbyggnadsarbete', '- Kraftuttag och hydraulik', and '- Applikationer'. At the bottom of the sidebar is a 'Collapse' button.

I framtiden kan man søke instruksjoner på chassisnummer.



Bodybuilder konto- og passordinformasjon

Man får forslag etter hva man søker etter. Beklageligvis ikke på norsk. Man kan bruke svensk eller engelsk.

The screenshot displays the Scania Bodybuilder website interface. At the top left, the Scania logo and 'TRUCK BODYBUILDER' are visible. A navigation bar includes links for HOME, REQUIREMENTS, INSTRUCTIONS, DRAWINGS AND 3D, TOOLS AND SERVICES, and FACTORY. A search bar in the top right contains the text 'arbete på chassi'. A dropdown menu is open, listing search results with 'INSTRUCTIONS' and 'LPORS' buttons for each. The results are:

- Kontrollpunkt 5, elektrisk installation VCA-systemet
- Allmänt
- Chassimodifieringar på batteriefordon
- ADR-dekal för elektrisk motorvärmare
- Allmänt om påbyggnadsgränssnitt
- Strömförsörjning på chassi

Below the search bar, there is a section titled 'Chassis number filter under construction'. It includes a 'Language' dropdown menu set to 'Select Language' and a 'Filters' section with icons for a document and a truck.



Bodybuilder konto- og passordinformasjon

NY RUTINE PÅ PÅLOGGING

Velkommen som bruker av Scantias påbyggerportal. Vi har opprettet en XDS-konto til deg, og du har fått følgende påloggingsinformasjon:

Scania XDS-brukernavn

Entra user ID: xds-brukernavn@scaniaweb.com

E-postadressen er ikke en ekte e-postadresse, den blir kun brukt til innlogging.

For å kunne håndtere passordbytte på denne kontoen selv, må du sette opp tofaktor med både SMS og Microsoft Authenticator App på din telefon. Under ser du hvordan du går frem for å sette opp dette.



Bodybuilder konto- og passordinformasjon

Oppsett av Microsoft Authenticator App som tofaktor (MFA) på myaccount.microsoft.com

For at du skal kunne logge deg på din Scania-konto må du sette opp både SMS og Authenticator App som tofaktor.

Dette gjør du ved å logge inn på:
<https://myaccount.microsoft.com> med brukernavn@scaniaweb.com og ditt passord, eller et midlertidig passord du har fått av oss.



← [redacted]@scaniaweb.com

Skriv inn passord

.....

[Jeg har glemt passordet](#)

[Bruk et sertifikat eller et smartkort](#)

Logg på

To get your Entra user ID, please contact customer support or your reporting manager



Bodybuilder konto- og passordinformasjon

Klikk Neste når du blir bedt om mer informasjon.



██████████@scaniaweb.com

Trenger mer informasjon

Organisasjonen trenger mer informasjon for å beskytte kontoen din

[Bruk en annen konto](#)

[Lær mer](#)

Neste

To get your Entra user ID, please contact customer support or your reporting manager



Bodybuilder konto- og passordinformasjon

Last ned Microsoft Authenticator appen på din telefon, om du ikke har den fra før, husk å tillate alle varslinger fra denne appen.
Klikk Neste

Sikre kontoen din

Microsoft Authenticator



Begynn ved å skaffe deg appen

Installer Microsoft Authenticator-appen på telefonen din. [Last ned nå](#)

Når du har installert Microsoft Authenticator-appen på enheten, velger du «Neste».

[Jeg vil bruke en annen godkjennerapp](#)

[Neste](#)

[Jeg vil konfigurere en annen metode](#)



Bodybuilder konto- og passordinformasjon

I Authenticator appen på mobilen klikker du på + øverst til høyre.
Velg Jobb- eller skolekonto, deretter valget Scan QR-kode.
Klikk neste.

Sikre kontoen din

Microsoft Authenticator



Konfigurer kontoen

Når du blir bedt om det, tillater du varslinger. Legg deretter til en konto og velg «Jobb eller skole».

[Tilbake](#) [Neste](#)

[Jeg vil konfigurere en annen metode](#)



Bodybuilder konto- og passordinformasjon

Skann QR-koden via Authenticator appen, fullfør ved å gjennomføre en test. Klikk neste.

Sikre kontoen din

Microsoft Authenticator

Skann QR-koden

Bruk Microsoft Authenticator-appen til å skanne QR-koden nedenfor. Dette kobler Microsoft Authenticator-appen til kontoen.

Når du har skannet QR-koden, velger du «Neste».



[Kan du ikke skanne bildet?](#)

[Tilbake](#) [Neste](#)

[Jeg vil konfigurere en annen metode](#)



Bodybuilder konto- og passordinformasjon

Klikk på neste, skriv deretter inn nummeret du får opp på skjermen (bilde 2) i Authenticator appen på mobiltelefonen for å teste løsningen.

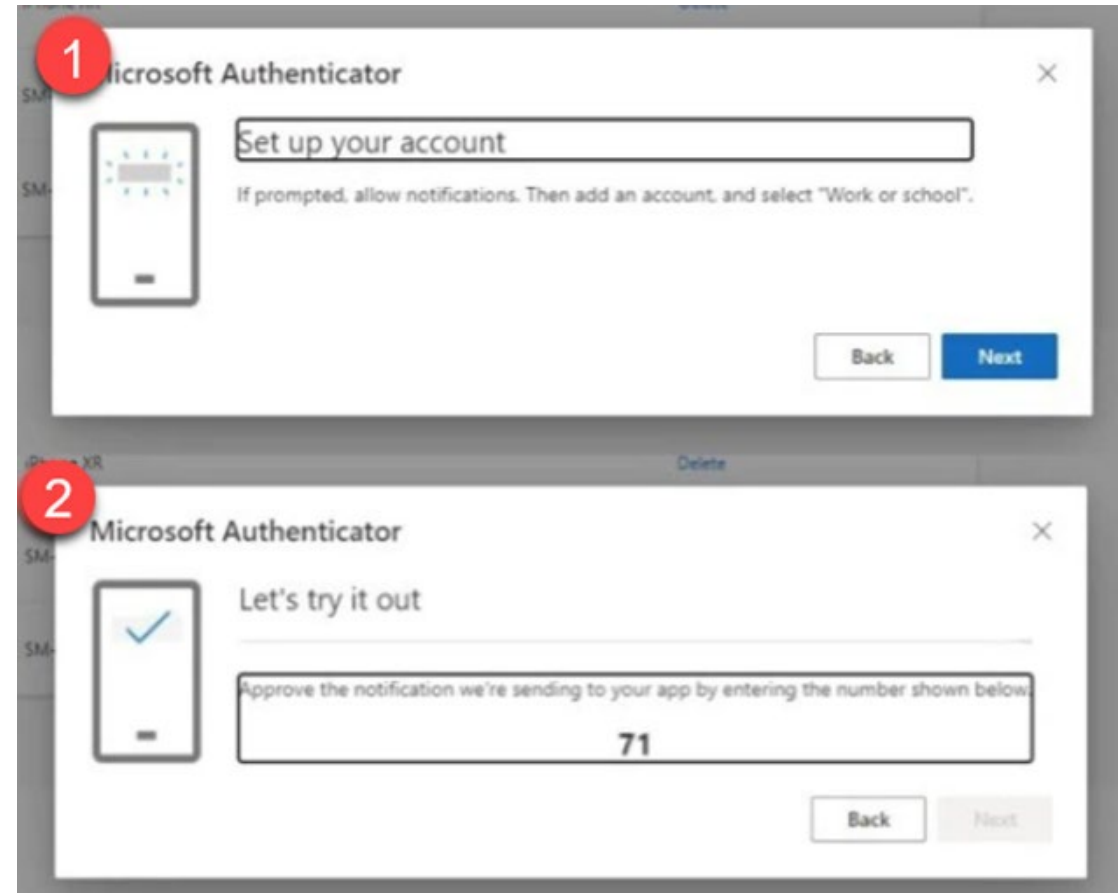



Bodybuilder konto- og passordinformasjon

Nå er du ferdig med å sette opp Authenticatorappen, og du vil bli bedt om å bytte passord slik at du får satt ditt eget. Nåværende passord er det passordet du har fra før, eller det midlertidige du har fått fra OSS.



██████████@scaniaweb.com

Oppdater passordet

Du må oppdatere passordet ditt fordi dette er første gang du logger deg på, eller fordi passordet ditt har utløpt.

Nåværende passord

Nytt passord

Bekreft passord

Logg på

To get your Entra user ID, please contact customer support or your reporting manager



Bodybuilder konto- og passordinformasjon

Velg nytt passord, følg disse reglene:

- Passord må ha minst 12 tegn, Passord må ha minst 6 bokstav(er)
- Du kan ikke gjenbruke noen av dine 24 forrige passord.
- Passord må ha minst 1 liten/små bokstav(er)
- Passordet må bestå av minst 3 tegntyper.
- Passord må ha minst 1 spesialtegn
- Passord må ha minst 2 siffer
- Passord må ha minst 1 stor(e) bokstav(er)
- Passordet sjekkes mot passordordboken.
- Passordet kan ikke inneholde visningsnavnet ditt
- Passordet kan ikke inneholde konto-ID-en din
- Unngå æ, ø og å i passordet ditt.



Bodybuilder konto- og passordinformasjon

Oppsett av SMS som tofaktor på myaccount.microsoft.com

For at du skal kunne logge deg på kontoen, hvis du mister eller bytter telefonen din, må du også sette opp SMS som 2-faktor i tillegg til Authenticator appen.

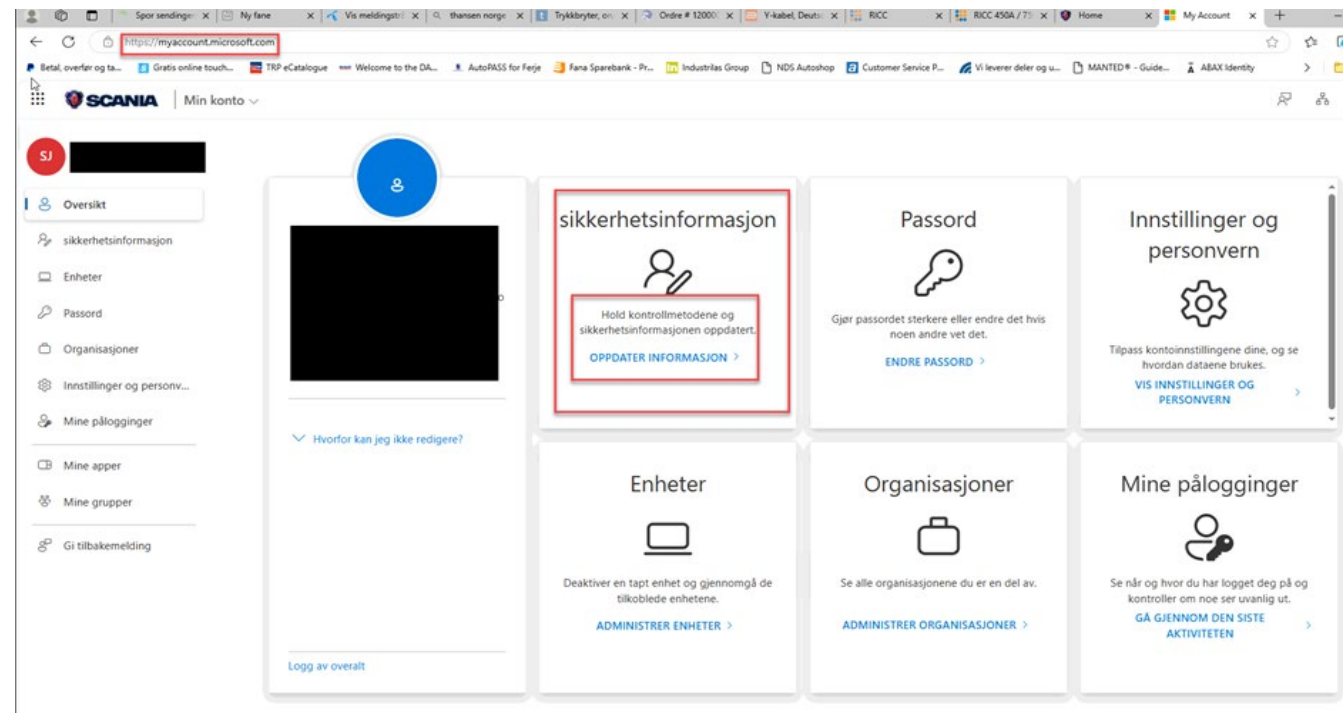

Du er nå innlogget på <https://myaccount.microsoft.com> med brukernavn@scaniaweb.com



Bodybuilder konto- og passordinformasjon

Under sikkerhetsinformasjon klikker du på Oppdater informasjon.

Bekreft innloggingen din med Authenticatorappen.

Klikk på Legg til en påloggingsmetode

Mine pålogginger ▾

sikkerhetsinformasjon

Dette er metodene du bruker for å logge deg på kontoen eller tilbakestille passordet.

Du bruker den mest anbefalte påloggingsmetoden der den gjelder.
Påloggingsmetode når den anbefalte ikke er tilgjengelig: Telefon – tekst +47 95040039 [Endre](#)

[+ Legg til en påloggingsmetode](#)



Bodybuilder konto- og passordinformasjon

Trykk på pilen slik at du får frem flere valg og kan velge telefon.

Norge +47 og ditt telefonnummer.

Du får da en sms med en tallkode. Bekreft koden i nettleseren.

Oppsettet er klart, og du kan nå bruke både SMS og Authenticator app som tofaktor.

Legg til en metode ×

Hvilken metode vil du legge til?

Velg en annen metode 

Avbryt

Legg til



Bodybuilder konto- og passordinformasjon

Innlogging til påbyggerportalen

Oppsettet er ferdig, du kan nå gå til <https://bodybuilder.scania.com>

Hvis du ikke automatisk blir innlogget, klikk på Login øverst til høyre.

Det kan gå litt tid fra du har satt passordet, til du kommer inn på påbyggerportalen.

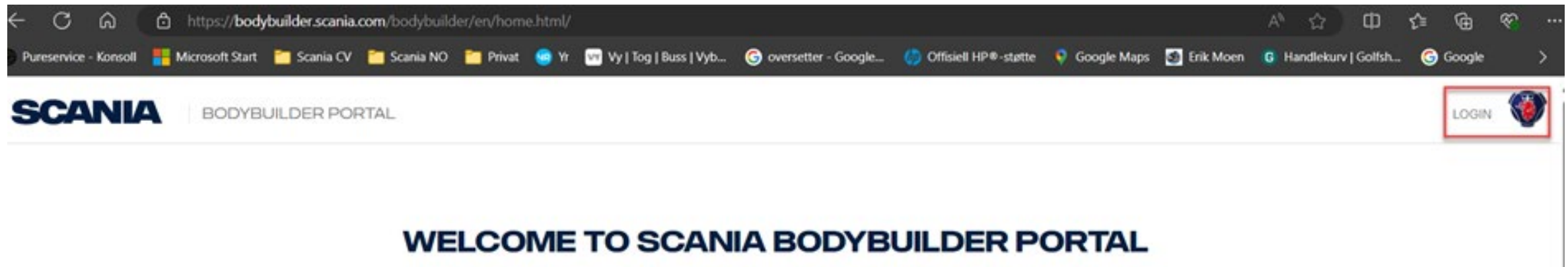



TAKK FOR OPPMERKSOMHETEN



SCANIA



SCANIA